

NEW PRODUCT RELEASE

Split Air Conditioner Slim Duct

Model:

- ARXG09KLLAP / AOEG09KBTB**
- ARXG12KLLAP / AOEG12KBTB**
- ARXG14KLLAP / AOEG14KBTB**
- ARXG18KLLAP / AOEG18KBTB**



ARXG09/12/14KLLAP



ARXG18KLLAP



Slim design

The slim design fits nicely into narrow spaces under the ceiling. Drain hose as standard accessory



Height **198 mm**
Built-in drain pump

Compact and lightweight outdoor unit

The compact and lightweight outdoor unit offers greater flexibility in the choice of installation location. This makes it easier to use this outdoor unit.

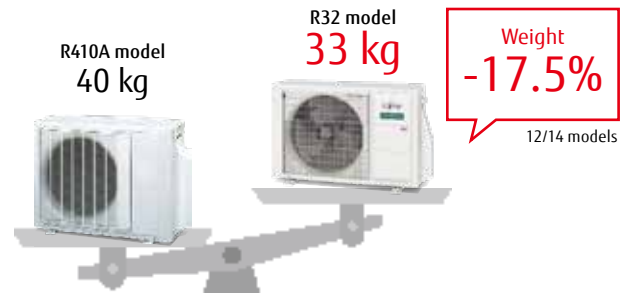

Wide range of static pressures

The use of a DC fan motor makes it possible to adjust the static pressure between 0 and 90 Pa. The static pressure range can be changed by a remote controller.



Static pressure range
0 to 90 Pa

Auto louver grille kit (Option)

The optional clean-looking flat Auto louver blends into any interior and provides a comfortable airflow.



Link up with a variety of central control system (Option)

Centralized control including facilities and equipment in addition to air conditioning is possible by linking up with MODBUS, KNX interfaces.



Central Control System



Specifications

Model No.	Indoor unit		ARXG09KLLAP	ARXG12KLLAP	ARXG14KLLAP	ARXG18KLLAP
	Outdoor unit		AOEG09KBTB	AOEG12KBTB	AOEG14KBTB	AOEG18KBTB
Power Source			Single-phase, ~230V, 50Hz			
Capacity	Cooling	kW	2.5 (0.9-3.2)	3.5 (0.9-4.4)	4.3 (0.9-5.4)	5.2 (0.9-5.9)
	Heating		3.2 (0.9-4.7)	4.1 (0.9-5.7)	5.0 (0.9-6.5)	6.0 (0.9-7.5)
UK Total Cooling / UK Sensible Cooling			2.37 / 1.86	3.39 / 2.54	4.12 / 3.13	5.01 / 3.69
Input Power	Cooling/Heating		0.60 / 0.79	0.93 / 1.08	1.28 / 1.32	1.55 / 1.62
EER	Cooling		4.17	3.76	3.36	3.35
COP	Heating		4.05	3.80	3.79	3.70
Pdesign	Cooling/Heating(-10°C)		2.5 / 2.6	3.5 / 3.4	4.3 / 3.8	5.2 / 4.4
SEER	Cooling		6.20	6.10	5.80	6.20
SCOP	Heating		4.30	4.00	3.90	4.10
Energy Efficiency Class	Cooling		A++	A++	A+	A++
	Heating		A+	A+	A	A+
Annual Energy Consumption	Cooling		141	201	259	293
	Heating		845	1,189	1,362	1,501
Moisture Removal			l/h	0.7	1.3	1.5
Sound Pressure Level	Indoor (Cooling)	H/M/L/Q	28 / 27 / 26 / 25	29 / 28 / 26 / 25	32 / 30 / 28 / 26	32 / 30 / 29 / 27
	Indoor (Heating)	H/M/L/Q	28 / 26 / 25 / 24	29 / 28 / 26 / 24	32 / 30 / 28 / 25	32 / 30 / 29 / 27
Sound Power Level	Outdoor(Cooling/Heating)	High	46 / 46	47 / 47	49 / 49	50 / 50
	Indoor(Cooling/Heating)	High	57/57	58/58	60/60	58/58
Airflow Rate	Indoor / Outdoor (Cooling)	High	600 / 1,480	650 / 1,580	800 / 1,670	940 / 2,160
	Indoor / Outdoor (Heating)	High	600 / 1,410	650 / 1,520	800 / 1,580	940 / 1,830
Static pressure range (Standard)			Pa	0 to 90 (25)	0 to 90 (25)	0 to 90 (25)
Net Dimensions H x W x D	Indoor		mm	198 x 700 x 620	198 x 700 x 620	198 x 900 x 620
	Outdoor		mm	542 x 799 x 290	542 x 799 x 290	542 x 799 x 290
Weight	Indoor		kg	17	17	20
	Outdoor		kg	32	33	33
Remote Controller Type			NO CONTROLLER SUPPLIED WITH THESE UNITS PLEASE ORDER SEPARATELY			
Interconnecting Cable (Suggested cable size 1.5mm)			3 Core + Earth			
Suggested MCB Size			A	10	16	16
Max. Operating Current			A	7.9	9.7	10.2
Power Supply To			Outdoor			
Connection Pipe Diameter (Liquid / Gas)			Inch	1/4 & 3/8	1/4 & 3/8	1/4 & 1/2
Max Pipe Length (Pre-Charge)			m	20 (15)	25 (15)	30 (20)
Max Height Difference				15	20	20
Refrigerant	Type (Global Warming Potential)		R32 (675)			
	Charge (CO2eq-T)		g	850 (0.574)		1020 (0.689)
Additional Charge			g/m	20		20
Operation Range	Cooling		°CDB			
	Heating		-15 to 24			

Optional parts

* For optional parts compatibility of Intesis devices, please refer to the optional parts compatibility list page M-102 to M-103.

Wired Remote Controller (Design type):	UTY-RVRY	WLAN adapter:	UTY-TFSX)3	Network Converter for single split (DC power supply type):	UTY-VTGX
Compact Wired Remote Controller:	UTY-RCRYZ1		FG-AC-WIF1Z1	Network Converter for single split (AC power supply type):	UTY-VTGXV
Wired Remote Controller (touch panel):	UTY-RNRYZ5	Silver Ion Filter:	UTD-HFTA (09-14)	Fresh Air Intake Kit:	UTZ-VXAA
Wired Remote Controller:	UTY-RVNYM		UTD-HFTB (18)	Auto Louvre Grille Kit:	UTD-GXSA-W (09-14)
Simple Remote Controller (without operation mode):	UTY-RHRY	External Switch Controller:	UTY-TERX		UTD-GXSB-W (18)
Simple Remote Controller:	UTY-RSRY	KNX® Converter:	UTY-VKSX	IR Receiver Unit:	UTY-LBTYM
Wireless Remote Controller:	UTY-LNTY	MODBUS® Converter:	UTY-VMSX	External Connect Kit:	UTY-XWZXZG
IR Receiver Unit:	UTY-LBTYM	BACnet® Converter:	FG-AC-BAC1Z1		

Dimensions

(Unit : mm)

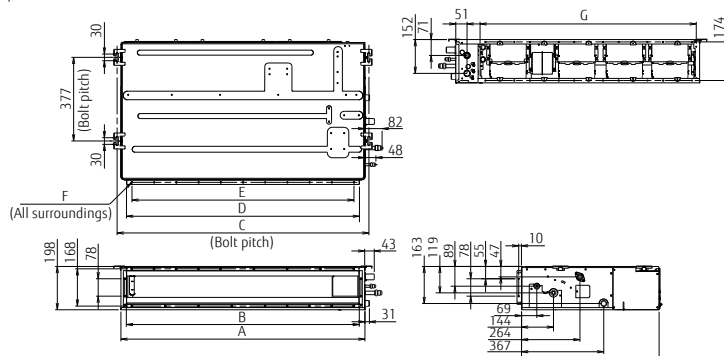

	ARXG09/12/14KLLAP	ARXG18KLLAP
A	700	900
B	650	850
C	734	934
D	650	850
E	P100x6=600	P100x8=800
F	18xØ5	22xØ5
G	574	774