

# NAVIGATOR®

Product Code: **BFDCV-15**

Product Description: **15 x 15MM DOUBLE CHECK VALVE DZR**

Product Specification:

Material: DZR Brass

Size: 15mm

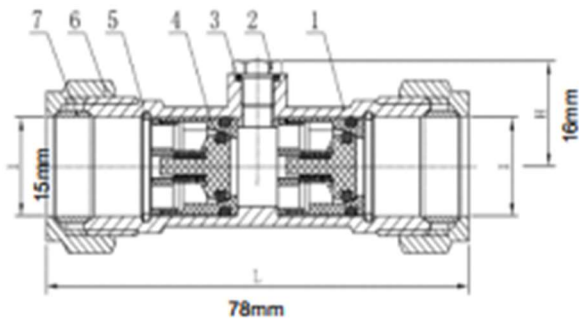

Size	L	H	Kgs
15mm	78	32	0.101

Part	Description	Material	Qty
1	Body	Brass DZR	1
2	Test Point Screw	Brass	1
3	O-Ring	EPDM	1
4	Cartridge	EPDM/ABS	2
5	Circlip	Stainless Steel	2
6	Compression Nut	Brass	2
7	Olive	Copper	2

## Technical Data

Field of Application	Suitable for Water Systems
Max. Working Pressure	85°C
Max. Working Temperature	10 Bar

Other Standards/Approvals