

# NAVIGATOR®

## PRODUCT DATA SHEET

Issue Number: **02**  
Date: 13/03/2019

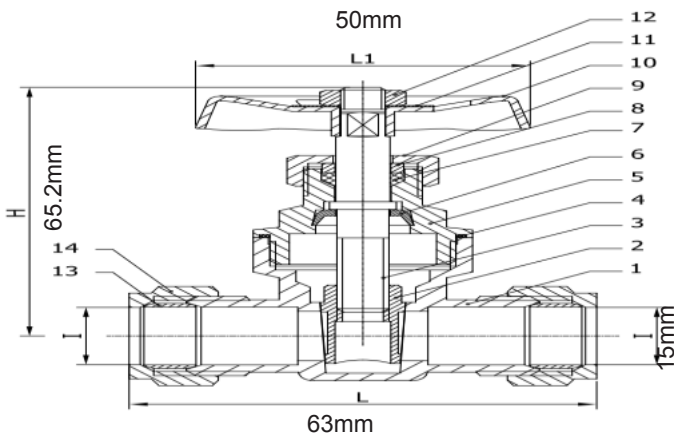

**Product Code: BFGV-15**

**Product Description: 15mm BS5154 Gate Valve**

**Product Type: Brassfoundry**

**Suitable For: Cold Water**

**Bag Qty: 1**

**Box Qty: 60**

**Item Weight: 0.2Kg**

**Material:**

1. BODY: Brass
2. DISC: Brass
3. STEM: Brass
4. WASHER: PTFE
5. BONNET: Brass
6. SCREW: Brass
7. PACKING: PTFE
8. GASKET: Brass
9. PRESSURE NUT: Brass
10. WHEEL HAND: Fe
11. PLATE: Al
12. SCREW: Fe
13. OLIVE: Brass
14. NUT: Brass

**Operating Temperature: -10°C to 85°C**

**Max Operating Pressure: 16 bar**

**Approvals: WRAS Approved**

This Technical Data Sheet is for Guidance only. As part of our commitment to continual improvement to our products, we reserve the right to amend this data sheet without prior notice. Please Note: weights are approximate and may vary.

# NAVIGATOR

Tel: +44 (0)1234 781234  
Fax: +44 (0)1234 781808  
Email: [sales@navigatormsl.com](mailto:sales@navigatormsl.com)  
[www.navigatormsl.co.uk](http://www.navigatormsl.co.uk)

Navigator MSL Ltd,  
Mill Road, Sharnbrook,  
Bedford, Bedfordshire,  
England, MK44 1NP.