

Service Manual

Air Conditioner

Indoor Unit
CS-MZ16ZKE
CS-MTZ16ZKE

Destination
Europe



Please file and use this manual together with the service manual for Model No. CU-2Z35TBE, CU-2Z41TBE, CU-2Z50TBE, CU-3Z52TBE, CU-3Z68TBE, CU-4Z68TBE, CU-4Z80TBE, CU-5Z90TBE, CU-2TZ41TBE, CU-2TZ50TBE, CU-3TZ52TBE, Order No. PAPAMY1702035CE, PAPAMY1703049CE, PAPAMY1710082CE, PAPAMY1802045CE, PAPAMY1802091CE.

WARNING

This service information is designed for experienced repair technicians only and is not designed for use by the general public. It does not contain warnings or cautions to advise non-technical individuals of potential dangers in attempting to service a product. Products powered by electricity should be serviced or repaired only by experienced professional technicians. Any attempt to service or repair the products dealt with in this service information by anyone else could result in serious injury or death.

IMPORTANT SAFETY NOTICE

There are special components used in this equipment which are important for safety. These parts are marked by  in the Schematic Diagrams, Circuit Board Diagrams, Exploded Views and Replacement Parts List. It is essential that these critical parts should be replaced with manufacturer's specified parts to prevent shock, fire or other hazards. Do not modify the original design without permission of manufacturer.

PRECAUTION OF LOW TEMPERATURE

In order to avoid frostbite, be assured of no refrigerant leakage during the installation or repairing of refrigerant circuit.

CAUTION

R32 REFRIGERANT – This Air Conditioner contains and operates with refrigerant R32.

THIS PRODUCT MUST ONLY BE INSTALLED OR SERVICED BY QUALIFIED PERSONNEL.

Refer to National, State, Territory and local legislation, regulations, codes, installation & operation manuals, before the installation, maintenance and/or service of this product.



TABLE OF CONTENTS

PAGE



1. Safety Precautions	3
2. Precaution for Using R32 Refrigerant	5
3. Specifications	10
4. Features	19
5. Location of Controls and Components	20
5.1 Indoor Unit	20
5.2 Remote Control	20
6. Dimensions	21
6.1 CS-MZ16ZKE	21
6.2 CS-MTZ16ZKE	22
7. Refrigeration Cycle Diagram	23
8. Block Diagram	24
9. Wiring Connection Diagram	25
9.1 CS-MZ16ZKE	25
9.2 CS-MTZ16ZKE	26
10. Electronic Circuit Diagram	27
10.1 CS-MZ16ZKE	27
10.2 CS-MTZ16ZKE	28
11. Printed Circuit Board	29
11.1 Indoor Unit	29
12. Installation Instruction	33
12.1 Select the Best Location	33
12.2 Indoor Unit	34
13. Installation Instruction	41
13.1 Select the Best Location	41
13.2 Indoor Unit	42
14. Operation Control (For Multi Split Connection)	48
14.1 Cooling operation	48
14.2 Soft Dry Operation	48
14.3 Heating Operation	48
14.4 Automatic Operation	49
14.5 Indoor Fan Motor Operation	49
14.6 Powerful Mode Operation	49
14.7 Auto Restart Control	49
14.8 Indication Panel	49
14.9 Mild Dry Cooling Operation	49
14.10 nanoe™X Operation	50
15. Servicing Mode	52
15.1 Auto OFF/ON Button	52
15.2 Heat Only Operation	53
15.3 Remote Control Button	55
16. Exploded View and Replacement Parts List	63
16.1 Indoor Unit	63

1. Safety Precautions















- Read the following “SAFETY PRECAUTIONS” carefully before installation and perform any servicing.
- This installation manual must be used together with another installation manual incorporated in applicable outdoor unit as complete full set of instructions.
- Confirm the type of gas used before installation.
- Electrical work must be installed by a licensed electrician. Be sure to use the correct rating of the power plug and main circuit for the model to be installed.
- The caution items stated here must be followed because these important contents are related to safety. The meaning of each indication used is as below. Incorrect installation due to ignoring of the instruction will cause harm or damage, and the seriousness is classified by the following indications.

 WARNING	This indication shows the possibility of causing death or serious injury.
 CAUTION	This indication shows the possibility of causing injury or damage to properties only.

- The items to be followed are classified by the symbols:

	Symbol with white background denotes item that is PROHIBITED.
 	Symbol with dark background denotes item that must be carried out.





- Carry out test running to confirm that no abnormality occurs after the installation. Then, explain to user the operation, care and maintenance as stated in instructions. Please remind the customer to keep the operating instructions for future reference.

 WARNING		
1.	Do not use means to accelerate the defrosting process or to clean, other than those recommended by the manufacturer. Any unfit method or using incompatible material may cause product damage, burst and serious injury.	
2.	Do not install outdoor unit near handrail of veranda. When installing air-conditioner unit on veranda of a high rise building, child may climb up to outdoor unit and cross over the handrail causing an accident.	
3.	Do not use unspecified cord, modified cord, joint cord or extension cord for power supply cord. Do not share the single outlet with other electrical appliances. Poor contact, poor insulation or over current will cause electrical shock or fire.	
4.	Do not tie up the power supply cord into a bundle by band. Abnormal temperature rise on power supply cord may happen.	
5.	Do not insert your fingers or other objects into the unit, high speed rotating fan may cause injury. 	
6.	Do not sit or step on the unit, you may fall down accidentally. 	
7.	Keep plastic bag (packaging material) away from small children, it may cling to nose and mouth and prevent breathing.  	
8.	When installing or relocating air conditioner, do not let any substance other than the specified refrigerant, eg. air etc mix into refrigeration cycle (piping). Mixing of air etc. will cause abnormal high pressure in refrigeration cycle and result in explosion, injury etc.	
9.	Do not pierce or burn as the appliance is pressurized. Do not expose the appliance to heat, flame, sparks, or other sources of ignition. Else, it may explode and cause injury or death.	
10.	Do not add or replace refrigerant other than specified type. It may cause product damage, burst and injury etc.	
11.	<ul style="list-style-type: none"> • For R32/R410A model, use piping, flare nut and tools which is specified for R32/R410A refrigerant. Using of existing (R22) piping, flare nut and tools may cause abnormally high pressure in the refrigerant cycle (piping), and possibly result in explosion and injury. For R32 and R410A, the same flare nut on the outdoor unit side and pipe can be used. • Since the working pressure for R32/R410A is higher than that of refrigerant R22 model, replacing conventional piping and flare nuts on the outdoor unit side are recommended. • If reuse piping is unavoidable, refer to instruction “IN CASE OF REUSING EXISTING REFRIGERANT PIPING” • Thickness of copper pipes used with R32/R410A must be more than 0.8 mm. Never use copper pipes thinner than 0.8 mm. • It is desirable that the amount of residual oil less than 40 mg/10 m. 	
12.	Engage authorized dealer or specialist for installation and servicing. If installation or servicing done by the user is incorrect, it will cause water leakage, electrical shock or fire.	
13.	For refrigeration system work, Install according to this installation instructions strictly. If installation is defective, it will cause water leakage, electrical shock or fire.	
14.	Use the attached accessories parts and specified parts for installation and servicing. Otherwise, it will cause the set to fall, water leakage, fire or electrical shock.	
15.	Install at a strong and firm location which is able to withstand weight of the set. If the strength is not enough or installation is not properly done, the set will drop and cause injury.	

 **WARNING**

16.	For electrical work, follow the national regulation, legislation and this installation instructions. An independent circuit and single outlet must be used. If electrical circuit capacity is not enough or defect found in the electrical work, it will cause electrical shock or fire.
17.	Do not use joint cable for indoor / outdoor connection cable. Use the specified indoor/outdoor connection cable, refer to instruction CONNECT THE CABLE TO THE INDOOR UNIT and connect tightly for indoor/outdoor connection. Clamp the cable so that no external force will have impact on the terminal. If connection or fixing is not perfect, it will cause heat up or fire at the connection.
18.	Wire routing must be properly arranged so that control board cover is fixed properly. If control board cover is not fixed perfectly, it will cause fire or electrical shock.
19.	This equipment is strongly recommended to be installed with Earth Leakage Circuit Breaker (ELCB) or Residual Current Device (RCD), with sensitivity of 30 mA at 0.1 sec or less. Otherwise, it may cause electrical shock and fire in case of equipment breakdown or insulation breakdown.
20.	During installation, install the refrigerant piping properly before running the compressor. Operation of compressor without fixing refrigeration piping and valves at opened position will cause suck-in of air, abnormal high pressure in refrigeration cycle and result in explosion, injury etc.
21.	During pump down operation, stop the compressor before removing the refrigeration piping. Removal of refrigeration piping while compressor is operating and valves are opened will cause suck-in of air, abnormal high pressure in refrigeration cycle and result in explosion, injury etc.
22.	Tighten the flare nut with torque wrench according to specified method. If the flare nut is over-tightened, after a long period, the flare may break and cause refrigerant gas leakage.
23.	After completion of installation or servicing, confirm there is no leakage of refrigerant gas. It may generate toxic gas when the refrigerant contacts with fire.
24.	Ventilate if there is refrigerant gas leakage during operation. It may cause toxic gas when the refrigerant contacts with fire.
25.	Be aware that refrigerants may not contain an odour.
26.	This equipment must be properly earthed. Earth line must not be connected to gas pipe, water pipe, earth of lightning rod and telephone. Otherwise, it may cause electrical shock in case of equipment breakdown or insulation breakdown.
27.	Do not modify the machine, part, material during repairing service.
28.	If wiring unit is supplied as repairing part, do not repair or connect the wire even only partial wire break. Exchange the whole wiring unit.
29.	Do not wrench the fasten terminal. Pull it out or insert it straightly.
30.	Must not use other parts except original parts describe in catalog and manual.

 **CAUTION**

1.	Do not install the unit in a place where leakage of flammable gas may occur. In case gas leaks and accumulates at surrounding of the unit, it may cause fire. 
2.	Prevent liquid or vapor from entering sumps or sewers since vapor is heavier than air and may form suffocating atmospheres. 
3.	Do not release refrigerant during piping work for installation or servicing, re-installation and during repairing refrigeration parts. Take care of the liquid refrigerant, it may cause frostbite. 
4.	Do not install this appliance in a laundry room or other location where water may drip from the ceiling, etc. 
5.	Do not touch the sharp aluminium fin, sharp parts may cause injury. 
6.	Carry out drainage piping as mentioned in installation instructions. If drainage is not perfect, water may enter the room and damage the furniture.
7.	Select an installation location which is easy for maintenance. Incorrect installation, service or repair of this air conditioner may increase the risk of rupture and this may result in loss damage or injury and/or property.
8.	Installation or servicing work. It may need two people to carry out the installation or servicing work.
9.	Keep any required ventilation openings clear of obstruction.
10.	Pb free solder has a higher melting point than standard solder; typically the melting point is 50°F – 70°F (30°C – 40°C) higher. Please use a high temperature solder iron. In case of the soldering iron with temperature control, please set it to 700 ± 20°F (370 ± 10°C). Pb free solder will tend to splash when heated too high (about 1100°F / 600°C).

2. Precaution for Using R32 Refrigerant

- Pay careful attention to the following precaution points and the installation work procedures.

 WARNING	
1.	When connecting flare at indoor side, make sure that the flare connection is used only once, if torqued up and released, the flare must be remade. Once the flare connection was torqued up correctly and leak test was made, thoroughly clean and dry the surface to remove oil, dirt and grease by following instructions of silicone sealant. Apply neutral cure (Alkoxy type) & ammonia-free silicone sealant that is noncorrosive to copper & brass to the external of the flared connection to prevent the ingress of moisture on both the gas & liquid sides. (Moisture may cause freezing and premature failure of the connection)
2.	The appliance shall be stored, installed and operated in a well ventilated room with indoor floor area larger than A_{min} (m ²) [refer Table A] and without any continuously operating ignition source. Keep away from open flames, any operating gas appliances or any operating electric heater. Else, it may explode and cause injury or death.
3.	The mixing of different refrigerants within a system is prohibited. Models that use refrigerant R32 and R410A have a different charging port thread diameter to prevent erroneous charging with refrigerant R22 and for safety. Therefore, check beforehand. [The charging port thread diameter for R32 and R410A is 12.7 mm (1/2 inch).]
4.	Ensure that foreign matter (oil, water, etc.) does not enter the piping. Also, when storing the piping, securely seal the opening by pinching, taping, etc. (Handling of R32 is similar to R410A.)
5.	Operation, maintenance, repairing and refrigerant recovery should be carried out by trained and certified personnel in the use of flammable refrigerants and as recommended by the manufacturer. Any personnel conducting an operation, servicing or maintenance on a system or associated parts of the equipment should be trained and certified.
6.	Any part of refrigerating circuit (evaporators, air coolers, AHU, condensers or liquid receivers) or piping should not be located in the proximity of heat sources, open flames, operating gas appliance or an operating electric heater.
7.	The user/owner or their authorized representative shall regularly check the alarms, mechanical ventilation and detectors, at least once a year, where as required by national regulations, to ensure their correct functioning.
8.	A logbook shall be maintained. The results of these checks shall be recorded in the logbook.
9.	In case of ventilations in occupied spaces shall be checked to confirm no obstruction.
10.	Before a new refrigerating system is put into service, the person responsible for placing the system in operation should ensure that trained and certified operating personnel are instructed on the basis of the instruction manual about the construction, supervision, operation and maintenance of the refrigerating system, as well as the safety measures to be observed, and the properties and handling of the refrigerant used.
11.	The general requirement of trained and certified personnel are indicated as below: a) Knowledge of legislation, regulations and standards relating to flammable refrigerants; and, b) Detailed knowledge of and skills in handling flammable refrigerants, personal protective equipment, refrigerant leakage prevention, handling of cylinders, charging, leak detection, recovery and disposal; and, c) Able to understand and to apply in practice the requirements in the national legislation, regulations and Standards; and, d) Continuously undergo regular and further training to maintain this expertise.
12.	Air-conditioner piping in the occupied space shall be installed in such a way to protect against accidental damage in operation and service.
13.	Precautions shall be taken to avoid excessive vibration or pulsation to refrigerating piping.
14.	Ensure protection devices, refrigerating piping and fittings are well protected against adverse environmental effects (such as the danger of water collecting and freezing in relief pipes or the accumulation of dirt and debris).
15.	Expansion and contraction of long runs piping in refrigerating systems shall be designed and installed securely (mounted and guarded) to minimize the likelihood hydraulic shock damaging the system.
16.	Protect the refrigerating system from accidental rupture due to moving furniture or reconstruction activities.
17.	To ensure no leaking, field-made refrigerant joints indoors shall be tightness tested. The test method shall have a sensitivity of 5 grams per year of refrigerant or better under a pressure of at least 0,25 times the maximum allowable pressure (>1.04MPa, max 4.15MPa). No leak shall be detected.

 CAUTION

General

1.
 - Must ensure the installation of pipe-work shall be kept to a minimum. Avoid use dented pipe and do not allow acute bending.
 - Must ensure that pipe-work shall be protected from physical damage.
 - Must comply with national gas regulations, state municipal rules and legislation. Notify relevant authorities in accordance with all applicable regulations.
 - Must ensure mechanical connections be accessible for maintenance purposes.
 - In cases that require mechanical ventilation, ventilation openings shall be kept clear of obstruction.
 - When disposal of the product, do follow to the precautions in #12 and comply with national regulations.
 - In case of field charge, the effect on refrigerant charge caused by the different pipe length has to be quantified, measured and labelled.
 - Always contact to local municipal offices for proper handling.
 - Ensure the actual refrigerant charge is in accordance with the room size within which the refrigerant containing parts are installed.
 - Ensure refrigerant charge not to leak.
 - Wear appropriate protective equipment, including respiratory protection, as conditions warrant.
 - Keep all sources of ignition and hot metal surfaces away.

Servicing

2.
 - 2-1. Qualification of workers
 - Any qualified person who is involved with working on or breaking into a refrigerant circuit should hold a current valid certificate from an industry-accredited assessment authority, which authorizes their competence to handle refrigerants safely in accordance with an industry recognized assessment specification.
 - Servicing shall only be performed as recommended by the equipment manufacturer. Maintenance and repair requiring the assistance of other skilled personnel shall be carried out under the supervision of the person competent in the use of flammable refrigerants.
 - Servicing shall be performed only as recommended by the manufacturer.
 - The system is inspected, regularly supervised and maintained by a trained and certified service personnel who is employed by the person user or party responsible.
 - 2-2. Checks to the area
 - Prior to beginning work on systems containing flammable refrigerants, safety checks are necessary to ensure that the risk of ignition is minimised.
 - For repair to the refrigerating system, the precautions in #2-3 to #2-7 must be followed before conducting work on the system.
 - 2-3. Work procedure
 - Work shall be undertaken under a controlled procedure so as to minimize the risk of a flammable gas or vapour being present while the work is being performed.
 - 2-4. General work area
 - All maintenance staff and others working in the local area shall be instructed and supervised on the nature of work being carried out.
 - Avoid working in confined spaces. Always ensure away from source, at least 2 meter of safety distance, or zoning of free space area of at least 2 meter in radius.
 - 2-5. Checking for presence of refrigerant
 - The area shall be checked with an appropriate refrigerant detector prior to and during work, to ensure the technician is aware of potentially flammable atmospheres.
 - Ensure that the leak detection equipment being used is suitable for use with flammable refrigerants, i.e. non sparking, adequately sealed or intrinsically safe.
 - In case of leakage/spillage happened, immediately ventilate area and stay upwind and away from spill/release.
 - In case of leakage/spillage happened, do notify persons down wind of the leaking/spill, isolate immediate hazard area and keep unauthorized personnel out.
 - 2-6. Presence of fire extinguisher
 - If any hot work is to be conducted on the refrigerating equipment or any associated parts, appropriate fire extinguishing equipment shall be available at hand.
 - Have a dry powder or CO₂ fire extinguisher adjacent to the charging area.
 - 2-7. No ignition sources
 - No person carrying out work in relation to a refrigerating system which involves exposing any pipe work that contains or has contained flammable refrigerant shall use any sources of ignition in such a manner that it may lead to the risk of fire or explosion. He/She must not be smoking when carrying out such work.
 - All possible ignition sources, including cigarette smoking, should be kept sufficiently far away from the site of installation, repairing, removing and disposal, during which flammable refrigerant can possibly be released to the surrounding space.
 - Prior to work taking place, the area around the equipment is to be surveyed to make sure that there are no flammable hazards or ignition risks.
 - "No Smoking" signs shall be displayed.
 - 2-8. Ventilated area
 - Ensure that the area is in the open or that it is adequately ventilated before breaking into the system or conducting any hot work.
 - A degree of ventilation shall continue during the period that the work is carried out.
 - The ventilation should safely disperse any released refrigerant and preferably expel it externally into the atmosphere.



2-9. Checks to the refrigerating equipment

- Where electrical components are being changed, they shall be fit for the purpose and to the correct specification.
- At all times the manufacturer's maintenance and service guidelines shall be followed.
- If in doubt consult the manufacturer's technical department for assistance.
- The following checks shall be applied to installations using flammable refrigerants.
 - The actual refrigerant charge is in accordance with the room size within which the refrigerant containing parts are installed.
 - The ventilation machinery and outlets are operating adequately and are not obstructed.
 - If an indirect refrigerating circuit is being used, the secondary circuit shall be checked for the presence of refrigerant.
 - Marking to the equipment continues to be visible and legible. Markings and signs that are illegible shall be corrected.
 - Refrigerating pipe or components are installed in a position where they are unlikely to be exposed to any substance which may corrode refrigerant containing components, unless the components are constructed of materials which are inherently resistant to being corroded or are properly protected against being so corroded.

2-10. Checks to electrical devices

- Repair and maintenance to electrical components shall include initial safety checks and component inspection procedures.
- Initial safety checks shall include but not limit to:-
 - That capacitors are discharged: this shall be done in a safe manner to avoid possibility of sparking.
 - That there is no live electrical components and wiring are exposed while charging, recovering or purging the system.
 - That there is continuity of earth bonding.
- At all times the manufacturer's maintenance and service guidelines shall be followed.
- If in doubt consult the manufacturer's technical department for assistance.
- If a fault exists that could compromise safety, then no electrical supply shall be connected to the circuit until it is satisfactorily dealt with.
- If the fault cannot be corrected immediately but it is necessary to continue operation, an adequate temporary solution shall be used.
- The owner of the equipment must be informed or reported so all parties are advised thereafter.

Repairs to sealed components

- During repairs to sealed components, all electrical supplies shall be disconnected from the equipment being worked upon prior to any removal of sealed covers, etc.
 - If it is absolutely necessary to have an electrical supply to equipment during servicing, then a permanently operating form of leak detection shall be located at the most critical point to warn of a potentially hazardous situation.
 - Particular attention shall be paid to the following to ensure that by working on electrical components, the casing is not altered in such a way that the level of protection is affected. This shall include damage to cables, excessive number of connections, terminals not made to original specification, damage to seals, incorrect fitting of glands, etc.
- 3.
- Ensure that apparatus is mounted securely.
 - Ensure that seals or sealing materials have not degraded such that they no longer serve the purpose of preventing the ingress of flammable atmospheres.
 - Replacement parts shall be in accordance with the manufacturer's specifications.

NOTE: The use of silicon sealant may inhibit the effectiveness of some types of leak detection equipment. Intrinsically safe components do not have to be isolated prior to working on them.

Repair to intrinsically safe components

- Do not apply any permanent inductive or capacitance loads to the circuit without ensuring that this will not exceed the permissible voltage and current permitted for the equipment in use.
- 4.
- Intrinsically safe components are the only types that can be worked on while live in the presence of a flammable atmosphere.
 - The test apparatus shall be at the correct rating.
 - Replace components only with parts specified by the manufacturer. Unspecified parts by manufacturer may result ignition of refrigerant in the atmosphere from a leak.

Cabling

- 5.
- Check that cabling will not be subject to wear, corrosion, excessive pressure, vibration, sharp edges or any other adverse environmental effects.
 - The check shall also take into account the effects of aging or continual vibration from sources such as compressors or fans.

Detection of flammable refrigerants

- Under no circumstances shall potential sources of ignition be used in the searching or detection of refrigerant leaks.
 - A halide torch (or any other detector using a naked flame) shall not be used.
 - The following leak detection methods are deemed acceptable for all refrigerant systems.
 - No leaks shall be detected when using detection equipment with a sensitivity of 5 grams per year of refrigerant or better under a pressure of at least 0.25 times the maximum allowable pressure (>1.04MPa, max 4.15MPa) for example, a universal sniffer.
 - Electronic leak detectors may be used to detect flammable refrigerants, but the sensitivity may not be adequate, or may need re-calibration. (Detection equipment shall be calibrated in a refrigerant-free area.)
- 6.
- Ensure that the detector is not a potential source of ignition and is suitable for the refrigerant used.
 - Leak detection equipment shall be set at a percentage of the LFL of the refrigerant and shall be calibrated to the refrigerant employed and the appropriate percentage of gas (25 % maximum) is confirmed.
 - Leak detection fluids are also suitable for use with most refrigerants, for example, bubble method and fluorescent method agents. The use of detergents containing chlorine shall be avoided as the chlorine may react with the refrigerant and corrode the copper pipe-work.
 - If a leak is suspected, all naked flames shall be removed/extinguished.
 - If a leakage of refrigerant is found which requires brazing, all of the refrigerant shall be recovered from the system, or isolated (by means of shut off valves) in a part of the system remote from the leak. The precautions in #7 must be followed to remove the refrigerant.

 CAUTION

Removal and evacuation

- When breaking into the refrigerant circuit to make repairs – or for any other purpose – conventional procedures shall be used. However, it is important that best practice is followed since flammability is a consideration. The following procedure shall be adhered to:
remove refrigerant -> purge the circuit with inert gas -> evacuate -> purge with inert gas -> open the circuit by cutting or brazing.
- The refrigerant charge shall be recovered into the correct recovery cylinders.
- The system shall be purged with OFN to render the appliance safe. (remark: OFN = oxygen free nitrogen, type of inert gas)
- 7. • This process may need to be repeated several times.
- Compressed air or oxygen shall not be used for this task.
- Purging shall be achieved by breaking the vacuum in the system with OFN and continuing to fill until the working pressure is achieved, then venting to atmosphere, and finally pulling down to a vacuum.
- This process shall be repeated until no refrigerant is within the system.
- When the final OFN charge is used, the system shall be vented down to atmospheric pressure to enable work to take place.
- This operation is absolutely vital if brazing operations on the pipe work are to take place.
- Ensure that the outlet for the vacuum pump is not close to any potential ignition sources and there is ventilation available.

Charging procedures

- In addition to conventional charging procedures, the following requirements shall be followed.
 - Ensure that contamination of different refrigerants does not occur when using charging equipment.
 - Hoses or lines shall be as short as possible to minimize the amount of refrigerant contained in them.
 - Cylinders shall be kept in an appropriate position according to the instructions.
 - Ensure that the refrigerating system is earthed prior to charging the system with refrigerant.
 - Label the system when charging is complete (if not already).
 - Extreme care shall be taken not to over fill the refrigerating system.
- 8. • Prior to recharging the system it shall be pressure tested with OFN (refer to #7).
- The system shall be leak tested on completion of charging but prior to commissioning.
- A follow up leak test shall be carried out prior to leaving the site.
- Electrostatic charge may accumulate and create a hazardous condition when charging and discharging the refrigerant. To avoid fire or explosion, dissipate static electricity during transfer by grounding and bonding containers and equipment before charging/discharging.

Decommissioning

- Before carrying out this procedure, it is essential that the technician is completely familiar with the equipment and all its details.
- It is recommended good practice that all refrigerants are recovered safely.
- Prior to the task being carried out, an oil and refrigerant sample shall be taken in case analysis is required prior to re-use of recovered refrigerant.
- It is essential that electrical power is available before the task is commenced.
 - a) Become familiar with the equipment and its operation.
 - b) Isolate system electrically.
 - c) Before attempting the procedure ensure that:
 - mechanical handling equipment is available, if required, for handling refrigerant cylinders;
 - all personal protective equipment is available and being used correctly;
 - the recovery process is supervised at all times by a competent person;
 - recovery equipment and cylinders conform to the appropriate standards.
 - d) Pump down refrigerant system, if possible.
 - e) If a vacuum is not possible, make a manifold so that refrigerant can be removed from various parts of the system.
 - f) Make sure that cylinder is situated on the scales before recovery takes place.
 - g) Start the recovery machine and operate in accordance with instructions.
 - h) Do not over fill cylinders. (No more than 80 % volume liquid charge).
 - i) Do not exceed the maximum working pressure of the cylinder, even temporarily.
 - j) When the cylinders have been filled correctly and the process completed, make sure that the cylinders and the equipment are removed from site promptly and all isolation valves on the equipment are closed off.
 - k) Recovered refrigerant shall not be charged into another refrigerating system unless it has been cleaned and checked.
- 9. • Electrostatic charge may accumulate and create a hazardous condition when charging or discharging the refrigerant. To avoid fire or explosion, dissipate static electricity during transfer by grounding and bonding containers and equipment before charging/discharging.

Labelling

- 10. • Equipment shall be labelled stating that it has been de-commissioned and emptied of refrigerant.
- The label shall be dated and signed.
- Ensure that there are labels on the equipment stating the equipment contains flammable refrigerant.

 CAUTION

Recovery

- When removing refrigerant from a system, either for servicing or decommissioning, it is recommended good practice that all refrigerants are removed safely.
 - When transferring refrigerant into cylinders, ensure that only appropriate refrigerant recovery cylinders are employed.
 - Ensure that the correct number of cylinders for holding the total system charge are available.
 - All cylinders to be used are designated for the recovered refrigerant and labelled for that refrigerant (i.e. special cylinders for the recovery of refrigerant).
 - Cylinders shall be complete with pressure relief valve and associated shut-off valves in good working order.
 - Recovery cylinders are evacuated and, if possible, cooled before recovery occurs.
 - The recovery equipment shall be in good working order with a set of instructions concerning the equipment that is at hand and shall be suitable for the recovery of concerning the equipment that is at hand and shall be suitable for the recovery of flammable refrigerants.
- 11.
- In addition, a set of calibrated weighing scales shall be available and in good working order.
 - Hoses shall be complete with leak-free disconnect couplings and in good condition.
 - Before using the recovery machine, check that it is in satisfactory working order, has been properly maintained and that any associated electrical components are sealed to prevent ignition in the event of a refrigerant release. Consult manufacturer if in doubt.
 - The recovered refrigerant shall be returned to the refrigerant supplier in the correct recovery cylinder, and the relevant Waste Transfer Note arranged.
 - Do not mix refrigerants in recovery units and especially not in cylinders.
 - If compressors or compressor oils are to be removed, ensure that they have been evacuated to an acceptable level to make certain that flammable refrigerant does not remain within the lubricant.
 - The evacuation process shall be carried out prior to returning the compressor to the suppliers.
 - Only electric heating to the compressor body shall be employed to accelerate this process.
 - When oil is drained from a system, it shall be carried out safely.

3. Specifications

Model		Indoor		CS-MZ16ZKE		
		Outdoor		CU-3Z52TBE		
Performance Test Condition				EUROVENT		
Power Supply		Phase, Hz		Single, 50		
		V		230		
			Min.	Mid.	Max.	
Cooling	Capacity		kW	1.30	1.60	2.30
			BTU/h	4430	5460	7840
	Running Current		A	-	2.00	-
	Input Power		W	250	400	640
	Annual Consumption		kWh	-	200	-
	EER		W/W	5.20	4.00	3.59
	Indoor Noise (H / L / QLo)		Pressure level dB (A)	37 / 26 / 21		
			Power Level dB (A)	53 / - / -		
Heating	Capacity		kW	1.20	2.60	3.20
			BTU/h	4090	8870	10900
	Running Current		A	-	3.00	-
	Input Power		W	300	600	960
	COP		W/W	4.00	4.33	3.33
	Indoor Noise (H / L / QLo)		Pressure level dB (A)	38 / 27 / 21		
Power Level dB (A)			54 / - / -			
Indoor Fan	Type		Cross-Flow Fan			
	Material		ASG30			
	Motor Type		DC (8-poles)			
	Input Power		W	47.1		
	Output Power		W	30		
	Speed	QLo	Cool	rpm	500	
			Heat	rpm	510	
		Lo	Cool	rpm	580	
			Heat	rpm	620	
		Me	Cool	rpm	700	
			Heat	rpm	760	
		Hi	Cool	rpm	830	
			Heat	rpm	910	
	SHi	Cool	rpm	890		
Heat		rpm	970			
Moisture Removal			L/h (Pt/h)	1.0 (2.1)		
Indoor Airflow	QLo	Cool	m ³ /min (ft ³ /min)	5.94 (210)		
		Heat	m ³ /min (ft ³ /min)	6.10 (215)		
	Lo	Cool	m ³ /min (ft ³ /min)	7.23 (255)		
		Heat	m ³ /min (ft ³ /min)	7.87 (278)		
	Me	Cool	m ³ /min (ft ³ /min)	9.16 (323)		
		Heat	m ³ /min (ft ³ /min)	10.12 (357)		
	Hi	Cool	m ³ /min (ft ³ /min)	11.30 (400)		
		Heat	m ³ /min (ft ³ /min)	12.50 (440)		
	SHi	Cool	m ³ /min (ft ³ /min)	12.21 (431)		
		Heat	m ³ /min (ft ³ /min)	13.50 (477)		

Model		Indoor	CS-MZ16ZKE	
		Outdoor	CU-3Z52TBE	
Dimension	Height (I/D)	mm (inch)	295 (11-5/8)	
	Width (I/D)	mm (inch)	870 (34-9/32)	
	Depth (I/D)	mm (inch)	229 (9-1/32)	
Weight	Net (I/D)	kg (lb)	10 (22)	
Piping	Pipe Diameter (Liquid / Gas)	mm (inch)	6.35 (1/4) / 9.52 (3/8)	
Drain Hose	Inner Diameter	mm	16.7	
	Length	mm	650	
Indoor Heat Exchanger	Fin Material		Aluminium (Pre Coat)	
	Fin Type		Slit Fin	
	Row × Stage × FPI		2 × 17 × 21	
	Size (W × H × L)	mm	644.5 × 357 × 25.4	
Air Filter	Material		Polypropelene	
	Type		One-touch	
			Dry Bulb	Wet Bulb
Indoor Operation Range	Cooling	Maximum °C (°F)	32 (89.6)	23 (73.4)
		Minimum °C (°F)	16 (60.8)	11 (51.8)
	Heating	Maximum °C (°F)	30 (86.0)	–
		Minimum °C (°F)	16 (60.8)	–

- Cooling capacities are based on indoor temperature of 27°C Dry Bulb (80.6°F Dry Bulb), 19.0°C Wet Bulb (66.2°F Wet Bulb) and outdoor air temperature of 35°C DRY BULB (95°F Dry Bulb), 24°C Wet Bulb (75.2°F Wet Bulb)
- Heating capacities are based on indoor temperature of 20°C Dry Bulb (68°F Dry Bulb) and outdoor air temperature of 7°C Dry Bulb (44.6°F Dry Bulb), 6°C Wet Bulb (42.8°F Wet Bulb)
- Heating low temperature capacity, Input Power and COP measured at 230 V, indoor temperature 20°C, outdoor 2/1°C
- Heating extreme low temperature capacity, Input Power and COP measured at 230 V, indoor temperature 20°C, outdoor -7/-8°C
- Standby power consumption ≤12.0w (when switched OFF by remote control, except under self protection control).
- Specifications are subjected to change without prior notice for further improvement.

Model		Indoor		CS-MTZ16ZKE		
		Outdoor		CU-3TZ52TBE		
Performance Test Condition				EUROVENT		
Power Supply		Phase, Hz		Single, 50		
		V		230		
				Min.	Mid.	Max.
Cooling	Capacity		kW	1.30	1.60	2.30
			BTU/h	4430	5460	7840
	Running Current		A	-	2.10	-
	Input Power		W	250	420	660
	Annual Consumption		kWh	-	210	-
	EER		W/W	3.48	3.81	5.20
	Indoor Noise (H / L / QLo)		Pressure level dB (A)	38 / 27 / 22		
			Power Level dB (A)	54 / - / -		
Heating	Capacity		kW	1.20	2.60	3.20
			BTU/h	4090	8870	10900
	Running Current		A	-	3.10	-
	Input Power		W	300	640	1.00k
	COP		W/W	4.00	4.06	3.20
	Indoor Noise (H / L / QLo)		Pressure level dB (A)	39 / 28 / 24		
Power Level dB (A)			55 / - / -			
Indoor Fan	Type		Cross-Flow Fan			
	Material		ASG30			
	Motor Type		DC (8-poles)			
	Input Power		W	43.8		
	Output Power		W	40		
	Speed	QLo	Cool	rpm	550	
			Heat	rpm	640	
		Lo	Cool	rpm	710	
			Heat	rpm	730	
		Me	Cool	rpm	890	
			Heat	rpm	910	
		Hi	Cool	rpm	1020	
			Heat	rpm	1070	
	SHi	Cool	rpm	1070		
Heat		rpm	1120			
Moisture Removal			L/h (Pt/h)	1.0 (2.1)		
Indoor Airflow	QLo	Cool	m ³ /min (ft ³ /min)	4.97 (175)		
		Heat	m ³ /min (ft ³ /min)	5.99 (211)		
	Lo	Cool	m ³ /min (ft ³ /min)	6.78 (239)		
		Heat	m ³ /min (ft ³ /min)	7.01 (247)		
	Me	Cool	m ³ /min (ft ³ /min)	8.82 (311)		
		Heat	m ³ /min (ft ³ /min)	9.05 (320)		
	Hi	Cool	m ³ /min (ft ³ /min)	10.3 (365)		
		Heat	m ³ /min (ft ³ /min)	10.9 (385)		
	SHi	Cool	m ³ /min (ft ³ /min)	10.87 (384)		
		Heat	m ³ /min (ft ³ /min)	11.40 (403)		

Model		Indoor	CS-MTZ16ZKE	
		Outdoor	CU-3TZ52TBE	
Dimension	Height (I/D)	mm (inch)	290 (11-7/16)	
	Width (I/D)	mm (inch)	779 (30-11/16)	
	Depth (I/D)	mm (inch)	209 (8-1/4)	
Weight	Net (I/D)	kg (lb)	8 (18)	
Piping	Pipe Diameter (Liquid / Gas)	mm (inch)	6.35 (1/4) / 9.52 (3/8)	
Drain Hose	Inner Diameter	mm	16.7	
	Length	mm	550	
Indoor Heat Exchanger	Fin Material		Aluminium (Pre Coat)	
	Fin Type		Slit Fin	
	Row × Stage × FPI		2 × 14 × 17	
	Size (W × H × L)	mm	580 x 294 x 25.4	
Air Filter	Material		Polypropelene	
	Type		One-touch	
			Dry Bulb	Wet Bulb
Indoor Operation Range	Cooling	Maximum °C (°F)	32 (89.6)	23 (73.4)
		Minimum °C (°F)	16 (60.8)	11 (51.8)
	Heating	Maximum °C (°F)	30 (86.0)	-
		Minimum °C (°F)	16 (60.8)	-

- Cooling capacities are based on indoor temperature of 27°C Dry Bulb (80.6°F Dry Bulb), 19.0°C Wet Bulb (66.2°F Wet Bulb) and outdoor air temperature of 35°C DRY BULB (95°F Dry Bulb), 24°C Wet Bulb (75.2°F Wet Bulb)
- Heating capacities are based on indoor temperature of 20°C Dry Bulb (68°F Dry Bulb) and outdoor air temperature of 7°C Dry Bulb (44.6°F Dry Bulb), 6°C Wet Bulb (42.8°F Wet Bulb)
- Heating low temperature capacity, Input Power and COP measured at 230 V, indoor temperature 20°C, outdoor 2/1°C
- Heating extreme low temperature capacity, Input Power and COP measured at 230 V, indoor temperature 20°C, outdoor -7/-8°C
- Standby power consumption ≤12.0w (when switched OFF by remote control, except under self protection control).
- Specifications are subjected to change without prior notice for further improvement.

• **Multi Split Combination Possibility:**

- A single outdoor unit enables air conditioning of up to two separate rooms for CU-2Z35TBE, CU-2Z41TBE, CU-2Z50TBE.
- A single outdoor unit enables air conditioning of up to three separate rooms for CU-3Z68TBE, CU-3Z52TBE.

CONNECTABLE INDOOR UNIT			OUTDOOR UNIT											
			CU-2Z35TBE		CU-2Z41TBE		CU-2Z50TBE		CU-3Z68TBE			CU-3Z52TBE		
ROOM			A	B	A	B	A	B	A	B	C	A	B	C
TYPE														
Wall	1.6kW	CS-MZ16ZKE	•	•	•	•	•	•	•	•	•	•	•	•
	2.0kW	CS-Z20ZKEW	•	•	•	•	•	•	•	•	•	•	•	•
		CS-XZ20ZKEW CS-XZ20ZKEW-H	•	•	•	•	•	•	•	•	•	•	•	•
	2.5kW	CS-Z25ZKEW	•	•	•	•	•	•	•	•	•	•	•	•
		CS-XZ25ZKEW CS-XZ25ZKEW-H	•	•	•	•	•	•	•	•	•	•	•	•
	3.5kW	CS-Z35ZKEW	•	-	•	-	•	•	•	•	•	•	•	•
CS-XZ35ZKEW CS-XZ35ZKEW-H		•	-	•	-	•	•	•	•	•	•	•	•	-
4.2kW	CS-Z42ZKEW CS-XZ42ZKEW-H	-	-	-	-	•	-	•	•	-	•	•	-	
5.0kW	CS-Z50ZKEW CS-XZ50ZKEW	-	-	-	-	•	-	•	•	-	•	-	-	
Capacity range of connectable units			From 3.2kW to 6.0kW		From 3.2kW to 6.0kW		From 3.2kW to 7.7kW		From 4.5kW to 11.2kW			From 4.5kW to 9.5kW		
Pipe length	1 room maximum pipe length (m)		20		20		20		25			25		
	Allowable elevation (m)		10		10		10		15			15		
	Total allowable pipe length (m)		30		30		30		60			50		
	Total pipe length for maximum chargeless length (m)		20		20		20		30			30		
	Additional gas amount over chargeless length (g/m)		15		15		15		20			20		

Note: "•": Available

Remarks for CU-2Z35TBE / CU-2Z41TBE / CU-2Z50TBE

1. At least two indoor units must be connected.
2. The total nominal cooling capacity of indoor unit that will be connected to outdoor unit must be within connectable capacity range of indoor unit. (as shown in the table above)
Example: The indoor units' combination below is possible to connect to CU-2Z41TBE. (Total nominal capacity of indoor units is between 3.2kW to 6.0kW)
1) Two CS-MZ16ZKE only. (Total nominal cooling capacity is 3.2kW)

Remarks for CU-3Z68TBE / CU-3Z52TBE

1. At least two indoor units must be connected.
2. The total nominal cooling capacity of indoor unit that will be connected to outdoor unit must be within connectable capacity range of indoor unit. (as shown in the table above)
Example: The indoor units' combination below is possible to connect to CU-3Z68TBE. (Total nominal capacity of indoor units is between 4.5kW to 11.2kW)
1) Two CS-MZ16ZKE only. (Total nominal cooling capacity is 3.2kW)

• **Multi Split Combination Possibility:**

- A single outdoor unit enables air conditioning of up to four separate rooms for CU-4Z68TBE, CU-4Z80TBE.
- A single outdoor unit enables air conditioning of up to five separate rooms for CU-5Z90TBE.

CONNECTABLE INDOOR UNIT			OUTDOOR UNIT												
			CU-4Z68TBE				CU-4Z80TBE				CU-5Z90TBE				
TYPE	ROOM		A	B	C	D	A	B	C	D	A	B	C	D	E
			Wall	1.6kW	CS-MZ16ZKE	•	•	•	•	•	•	•	•	•	•
2.0kW	CS-Z20ZKEW	•		•	•	•	•	•	•	•	•	•	•	•	•
	CS-XZ20ZKEW CS-XZ20ZKEW-H	•		•	•	•	•	•	•	•	•	•	•	•	•
2.5kW	CS-Z25ZKEW	•		•	•	•	•	•	•	•	•	•	•	•	•
	CS-XZ25ZKEW CS-XZ25ZKEW-H	•		•	•	•	•	•	•	•	•	•	•	•	•
3.5kW	CS-Z35ZKEW	•		•	•	-	•	•	•	•	•	•	•	•	•
	CS-XZ35ZKEW CS-XZ35ZKEW-H	•		•	•	-	•	•	•	•	•	•	•	•	•
4.2kW	CS-Z42ZKEW CS-XZ42ZKEW-H	•	•	-	-	•	•	•	-	•	•	•	•	-	
5.0kW	CS-Z50ZKEW	•	•	-	-	•	•	-	-	•	•	•	-	-	
	CS-XZ50ZKEW	•	•	-	-	•	•	-	-	•	•	•	-	-	
7.1kW	CS-Z71ZKEW	-	-	-	-	•	•	-	-	•	•	-	-	-	
Capacity range of connectable units			From 4.5kW to 11.5kW				From 4.5kW to 14.7kW				From 4.5kW to 18.3kW				
Pipe length	1 room maximum pipe length (m)		25				25				25				
	Allowable elevation (m)		15				15				15				
	Total allowable pipe length (m)		60				70				80				
	Total pipe length for maximum chargeless length (m)		30				45				45				
	Additional gas amount over chargeless length (g/m)		20				20				20				
Note: "•" : Available															
<p>Remarks for CU-4Z68TBE / CU-4Z80TBE / CU-5Z90TBE</p> <p>1. At least two indoor units must be connected.</p> <p>2. The total nominal cooling capacity of indoor unit that will be connected to outdoor unit must be within connectable capacity range of indoor unit. (as shown in the table above)</p> <p>Example: The indoor units' combination below is possible to connect to CU-4Z80TBE. (Total nominal capacity of indoor units is between 4.5kW to 14.7kW)</p> <p>1) Two CS- MZ16ZKE only. (Total nominal cooling capacity is 3.2kW)</p>															

• **Multi Split Combination Possibility:**

- A single outdoor unit enables air conditioning of up to two separate rooms for CU-2Z35TBE, CU-2Z41TBE, CU-2Z50TBE.
- A single outdoor unit enables air conditioning of up to three separate rooms for CU-3Z68TBE, CU-3Z52TBE.

CONNECTABLE INDOOR UNIT			OUTDOOR UNIT											
			CU-2Z35TBE		CU-2Z41TBE		CU-2Z50TBE		CU-3Z68TBE			CU-3Z52TBE		
ROOM			A	B	A	B	A	B	A	B	C	A	B	C
TYPE														
Wall	1.6kW	CS-MTZ16ZKE	•	•	•	•	•	•	•	•	•	•	•	•
	2.0kW	CS-TZ20ZKEW CS-RZ20ZKEW	•	•	•	•	•	•	•	•	•	•	•	•
	2.5kW	CS-TZ25ZKEW CS-RZ25ZKEW	•	•	•	•	•	•	•	•	•	•	•	•
	3.5kW	CS-TZ35ZKEW CS-RZ35ZKEW	•	-	•	-	•	•	•	•	•	•	•	-
	4.2kW	CS-TZ42ZKEW	-	-	-	-	•	-	•	•	-	•	•	-
	5.0kW	CS-TZ50ZKEW CS-RZ50ZKEW	-	-	-	-	•	-	•	•	-	•	-	-
	6.0kW	CS-TZ60ZKEW	-	-	-	-	-	-	•	-	-	-	-	-
Capacity range of connectable units			From 3.2kW to 6.0kW		From 3.2kW to 6.0kW		From 3.2kW to 7.7kW		From 4.5kW to 11.2kW			From 4.5kW to 9.5kW		
Pipe length	1 room maximum pipe length (m)		20		20		20		25			25		
	Allowable elevation (m)		10		10		10		15			15		
	Total allowable pipe length (m)		30		30		30		60			50		
	Total pipe length for maximum chargeless length (m)		20		20		20		30			30		
	Additional gas amount over chargeless length (g/m)		15		15		15		20			20		
Note: "•": Available														
Remarks for CU-2Z35TBE / CU-2Z41TBE / CU-2Z50TBE														
1. At least two indoor units must be connected.														
2. The total nominal cooling capacity of indoor unit that will be connected to outdoor unit must be within connectable capacity range of indoor unit. (as shown in the table above)														
Example: The indoor units' combination below is possible to connect to CU-2Z41TBE. (Total nominal capacity of indoor units is between 3.2kW to 6.0kW)														
1) Two CS-MTZ16ZKE only. (Total nominal cooling capacity is 3.2kW)														
Remarks for CU-3Z68TBE / CU-3Z52TBE														
1. At least two indoor units must be connected.														
2. The total nominal cooling capacity of indoor unit that will be connected to outdoor unit must be within connectable capacity range of indoor unit. (as shown in the table above)														
Example: The indoor units' combination below is possible to connect to CU-3Z68TBE. (Total nominal capacity of indoor units is between 4.5kW to 11.2kW)														
1) Two CS-TZ25ZKEW only. (Total nominal cooling capacity is 5.0kW)														

• **Multi Split Combination Possibility:**

- A single outdoor unit enables air conditioning of up to four separate rooms for CU-4Z68TBE, CU-4Z80TBE.
- A single outdoor unit enables air conditioning of up to five separate rooms for CU-5Z90TBE.

CONNECTABLE INDOOR UNIT			OUTDOOR UNIT												
			CU-4Z68TBE				CU-4Z80TBE				CU-5Z90TBE				
TYPE	ROOM		A	B	C	D	A	B	C	D	A	B	C	D	E
	Wall	1.6kW	CS-MTZ16ZKE	•	•	•	•	•	•	•	•	•	•	•	•
2.0kW		CS-TZ20ZKEW CS-RZ20ZKEW	•	•	•	•	•	•	•	•	•	•	•	•	•
2.5kW		CS-TZ25ZKEW CS-RZ25ZKEW	•	•	•	•	•	•	•	•	•	•	•	•	•
3.5kW		CS-TZ35ZKEW CS-RZ35ZKEW	•	•	•	–	•	•	•	•	•	•	•	•	•
4.2kW		CS-TZ42ZKEW	•	•	–	–	•	•	•	–	•	•	•	•	–
5.0kW		CS-TZ50ZKEW CS-RZ50ZKEW	•	•	–	–	•	•	–	–	•	•	•	–	–
6.0kW		CS-TZ60ZKEW	•	–	–	–	•	•	–	–	•	•	•	–	–
7.1kW		CS-TZ71ZKEW	–	–	–	–	•	•	–	–	•	•	–	–	–
Capacity range of connectable units			From 4.5kW to 11.5kW				From 4.5kW to 14.7kW				From 4.5kW to 18.3kW				
Pipe length	1 room maximum pipe length (m)		25				25				25				
	Allowable elevation (m)		15				15				15				
	Total allowable pipe length (m)		60				70				80				
	Total pipe length for maximum chargeless length (m)		30				45				45				
	Additional gas amount over chargeless length (g/m)		20				20				20				
Note: “•” : Available															
Remarks for CU-4Z68TBE / CU-4Z80TBE / CU-5Z90TBE															
1. At least two indoor units must be connected.															
2. The total nominal cooling capacity of indoor unit that will be connected to outdoor unit must be within connectable capacity range of indoor unit. (as shown in the table above)															
Example: The indoor units' combination below is possible to connect to CU-4Z80TBE. (Total nominal capacity of indoor units is between 4.5kW to 14.7kW)															
1) Two CS-MTZ16ZKE only. (Total nominal cooling capacity is 3.2kW)															

• **Multi Split Combination Possibility:**

- A single outdoor unit enables air conditioning of up to two separate rooms for CU-2TZ41TBE, CU-2TZ50TBE.
- A single outdoor unit enables air conditioning of up to three separate rooms for CU-3TZ52TBE.

CONNECTABLE INDOOR UNIT			OUTDOOR UNIT						
			CU-2TZ41TBE		CU-2TZ50TBE		CU-3TZ52TBE		
ROOM			A	B	A	B	A	B	C
TYPE									
Wall	1.6kW	CS-MTZ16ZKE	•	•	•	•	•	•	•
	2.0kW	CS-TZ20ZKEW CS-RZ20ZKEW	•	•	•	•	•	•	•
	2.5kW	CS-TZ25ZKEW CS-RZ25ZKEW	•	•	•	•	•	•	•
	3.5kW	CS-TZ35ZKEW CS-RZ35ZKEW	•	–	•	•	•	•	–
	4.2kW	CS-TZ42ZKEW	–	–	•	–	•	•	–
	5.0kW	CS-TZ50ZKEW CS-RZ50ZKEW	–	–	•	–	•	–	–
Capacity range of connectable units			From 3.2kW to 6.0kW		From 3.2kW to 7.7kW		From 4.5kW to 9.5kW		
Pipe length	1 room maximum pipe length (m)		20		20		25		
	Allowable elevation (m)		10		10		15		
	Total allowable pipe length (m)		30		30		50		
	Total pipe length for maximum chargeless length (m)		20		20		30		
	Additional gas amount over chargeless length (g/m)		15		15		20		
Note: “•” : Available									
Remarks for CU-2TZ41TBE / CU-2TZ50TBE / CU-3TZ52TBE									
1. At least two indoor units must be connected.									
2. The total nominal cooling capacity of indoor unit that will be connected to outdoor unit must be within connectable capacity range of indoor unit. (as shown in the table above)									
Example: The indoor units' combination below is possible to connect to CU-3TZ52TBE. (Total nominal capacity of indoor units is between 4.5kW to 9.5kW)									
1) Two CS-TZ25ZKEW only. (Total nominal cooling capacity is 5.0kW)									

4. Features

- **Inverter Technology**
 - Wider output power range
 - Energy saving
 - Quick Cooling
 - Quick Heating
 - More precise temperature control
- **Environment Protection**
 - Non-ozone depletion substances refrigerant (R32)
- **Easy to use remote control**
- **Quality Improvement**
 - Random auto restart after power failure for safety restart operation
 - Gas leakage protection
 - Prevent compressor reverse cycle
 - Inner protector to protect compressor
 - Noise prevention during soft dry operation
- **Operation Improvement**
 - Quiet mode to reduce the indoor unit operating sound
 - Powerful mode to reach the desired room temperature quickly
 - 24-hour timer setting
 - nanoe™ X operation provides clean air, moisturises your skin and hair, deodorizes odours in the room
 - Mild Dry mode to improve humidity and moisture level during cooling operation
- **Serviceability Feature**
 - Activation and Deactivation Method for Heating Only Mode
 - Breakdown Self Diagnosis function
- **Communications network**

5. Location of Controls and Components

5.1 Indoor Unit

5.1.1 CS-MZ16ZKE

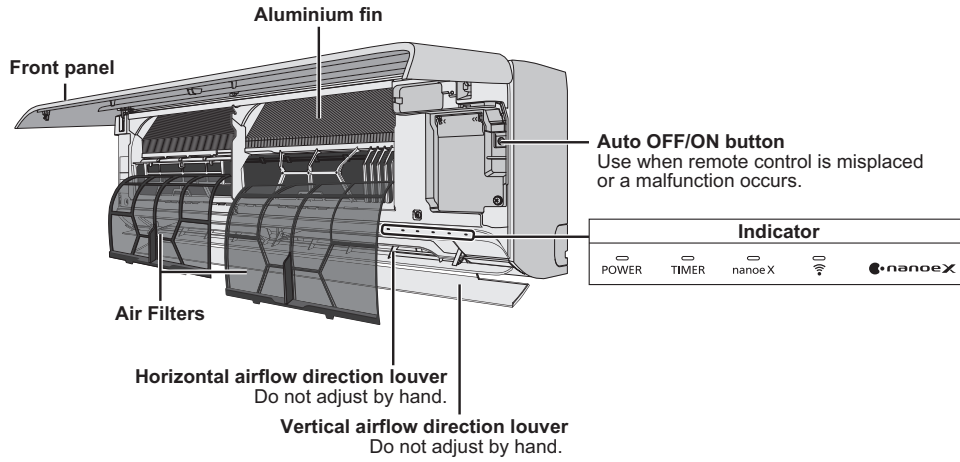

5.1.2 CS-MTZ16ZKE

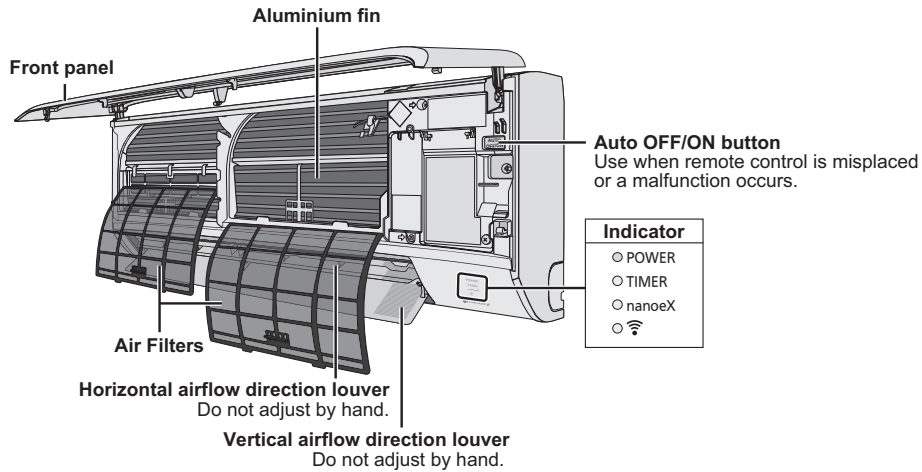

5.2 Remote Control

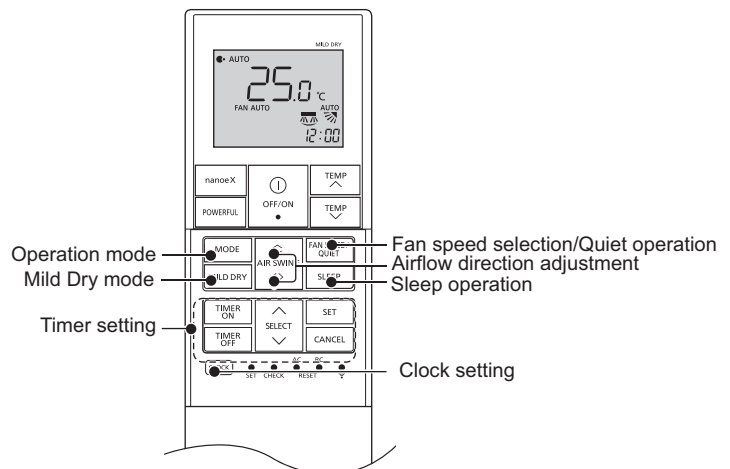
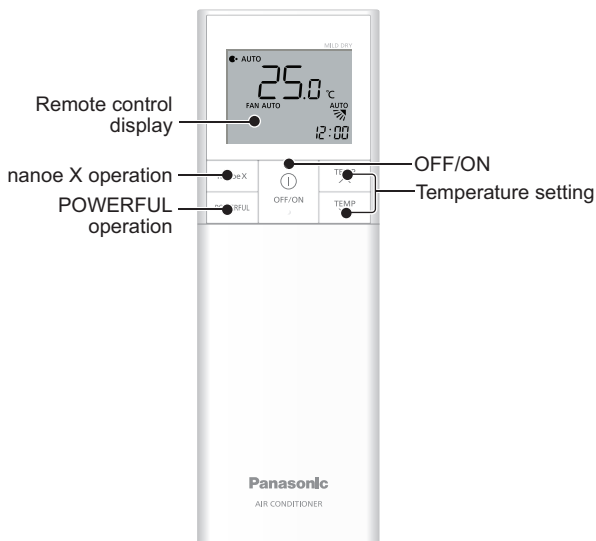

6. Dimensions

6.1 CS-MZ16ZKE

<Top View>

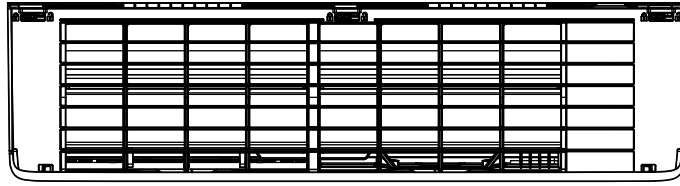

<Side View>

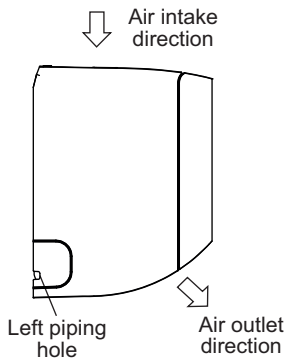

<Front View>

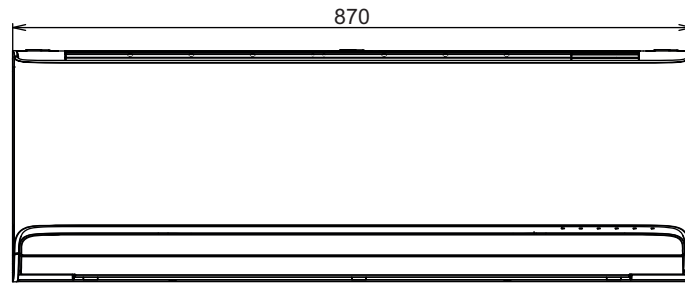

<Side View>

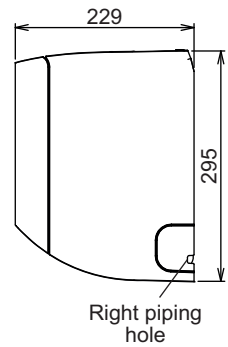

<Bottom View>

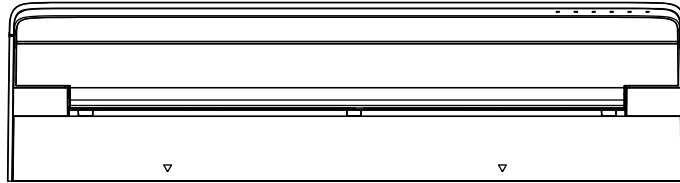

<Remote Control>

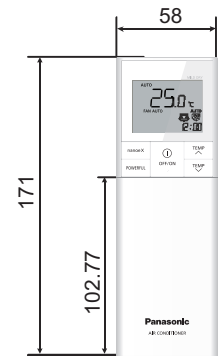

<Rear View>

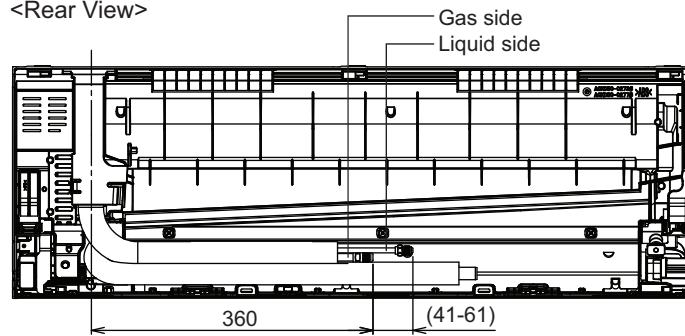

<Remote Control Holder>

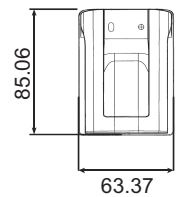

Relative position between the indoor unit and the installation plate <Front View>

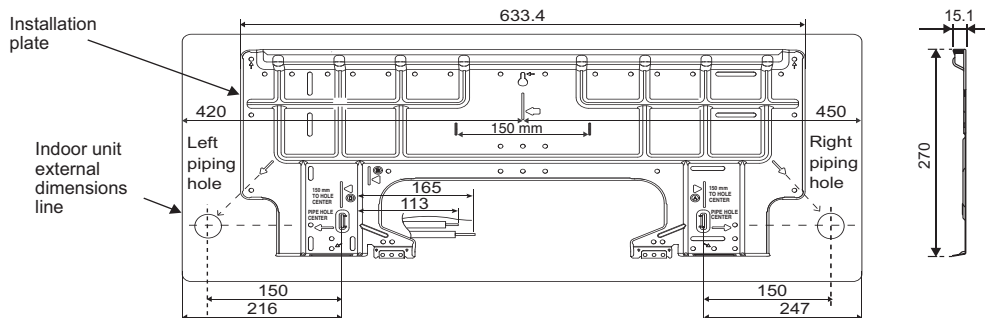

Unit: mm

6.2 CS-MTZ16ZKE

<Top View>

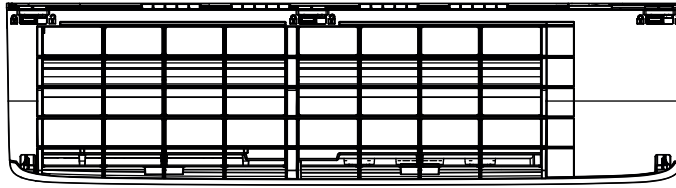

<Side View>

Air intake direction

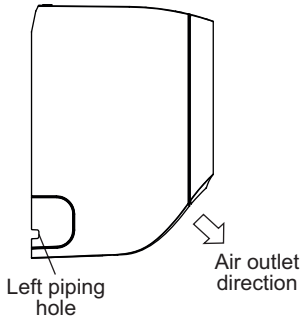

<Front View>

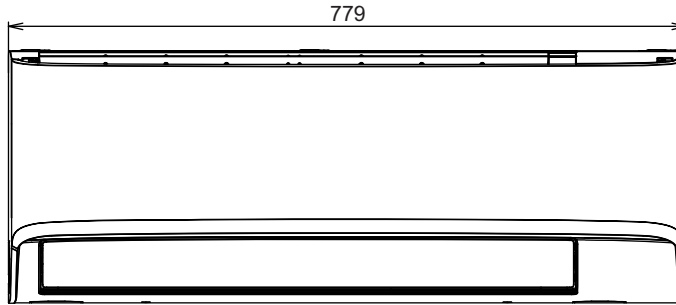

<Side View>

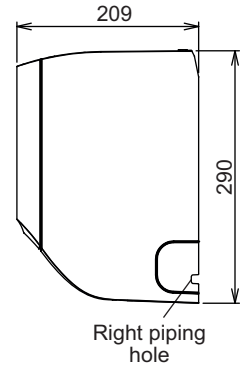

<Bottom View>

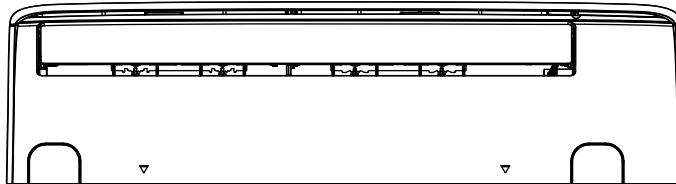

<Remote Control>

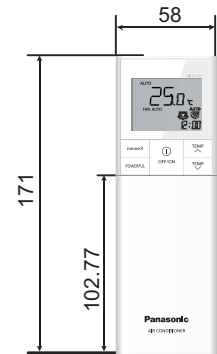

<Rear View>

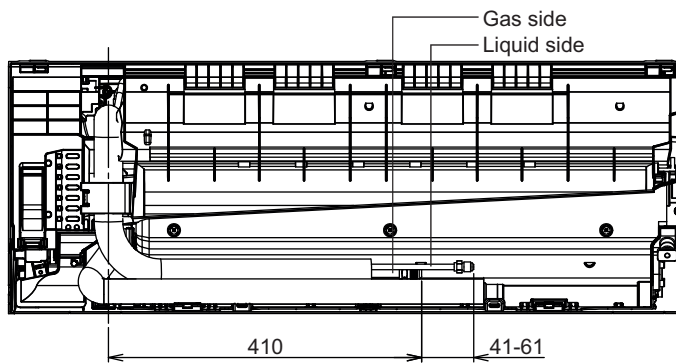

<Remote Control Holder>

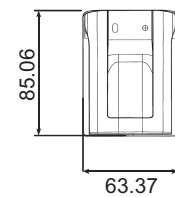

Relative position between the indoor unit and the installation plate <Front View>

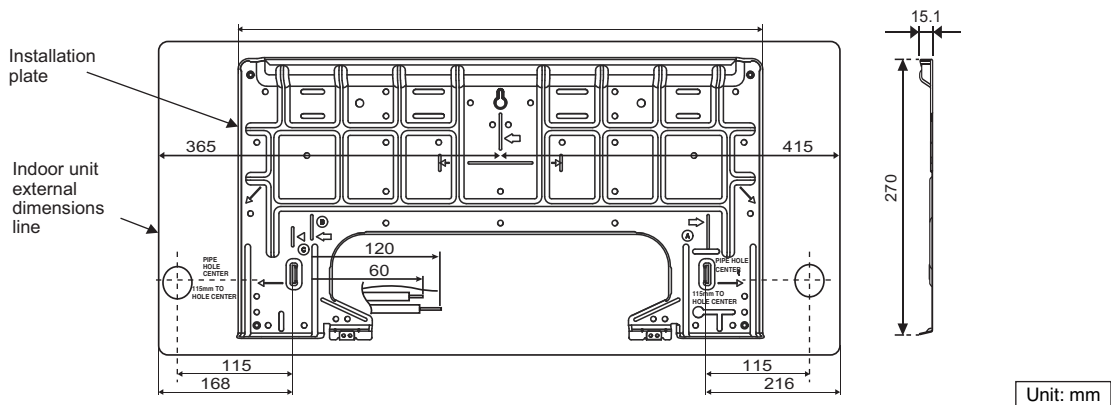

7. Refrigeration Cycle Diagram

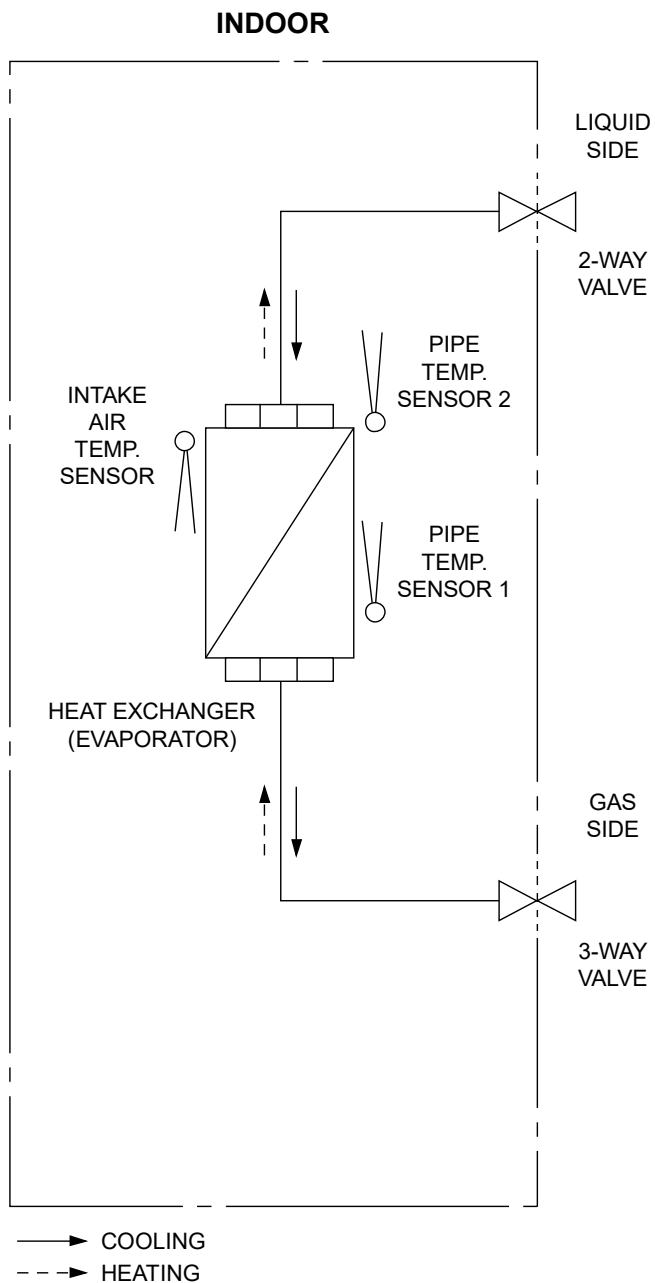

8. Block Diagram

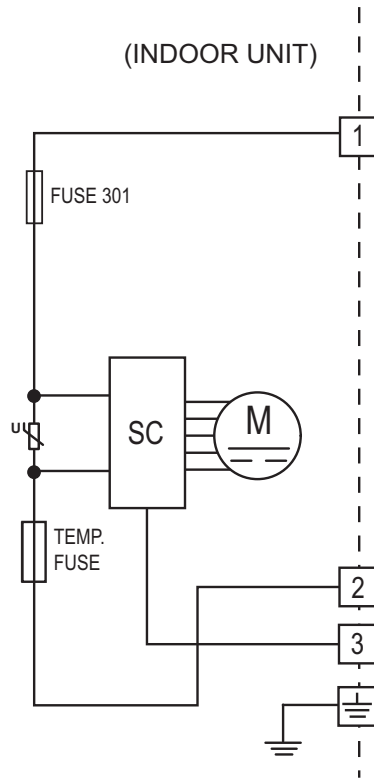

9. Wiring Connection Diagram

9.1 CS-MZ16ZKE

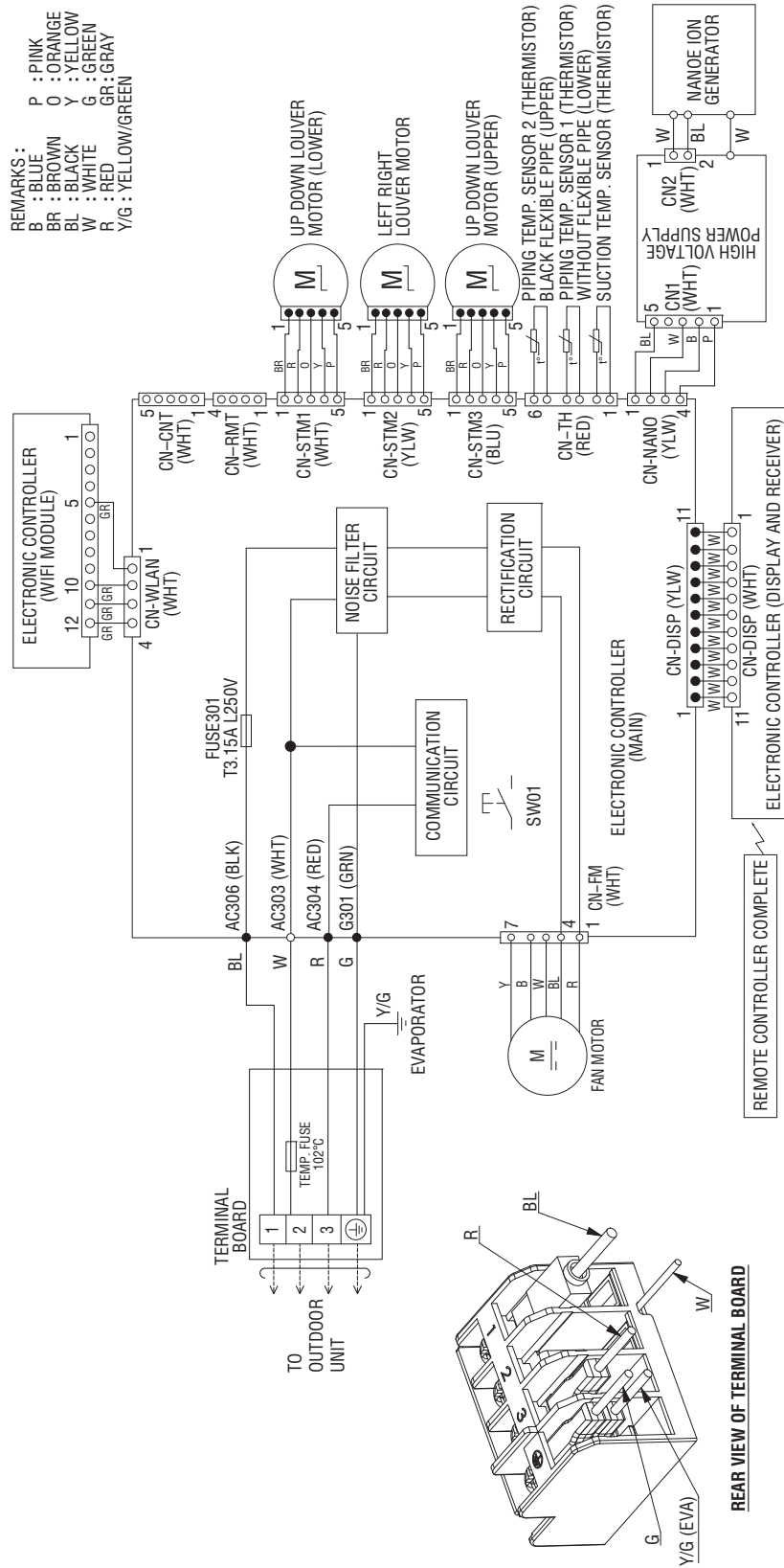

9.2 CS-MTZ16ZKE

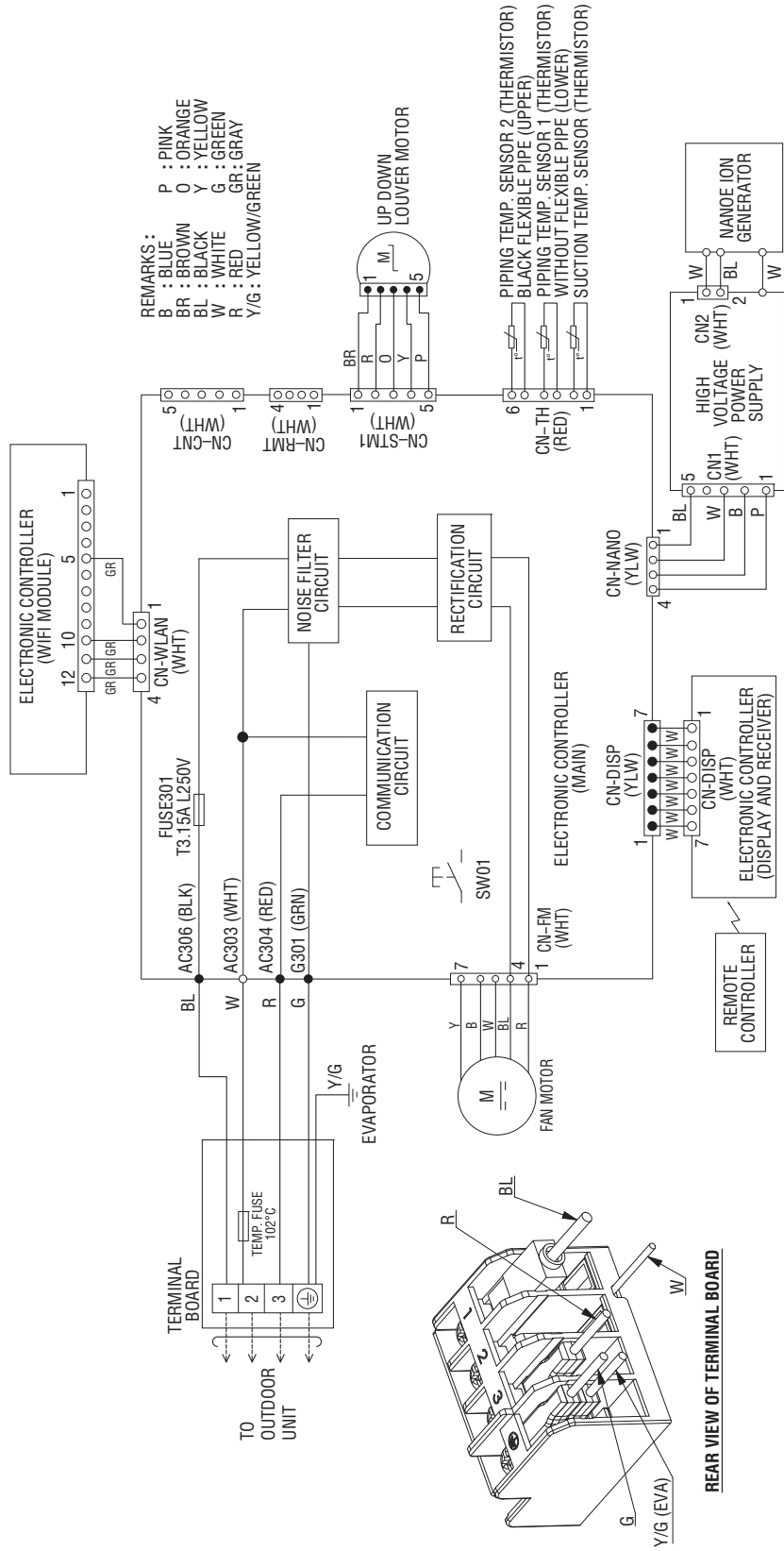

10. Electronic Circuit Diagram

10.1 CS-MZ16ZKE

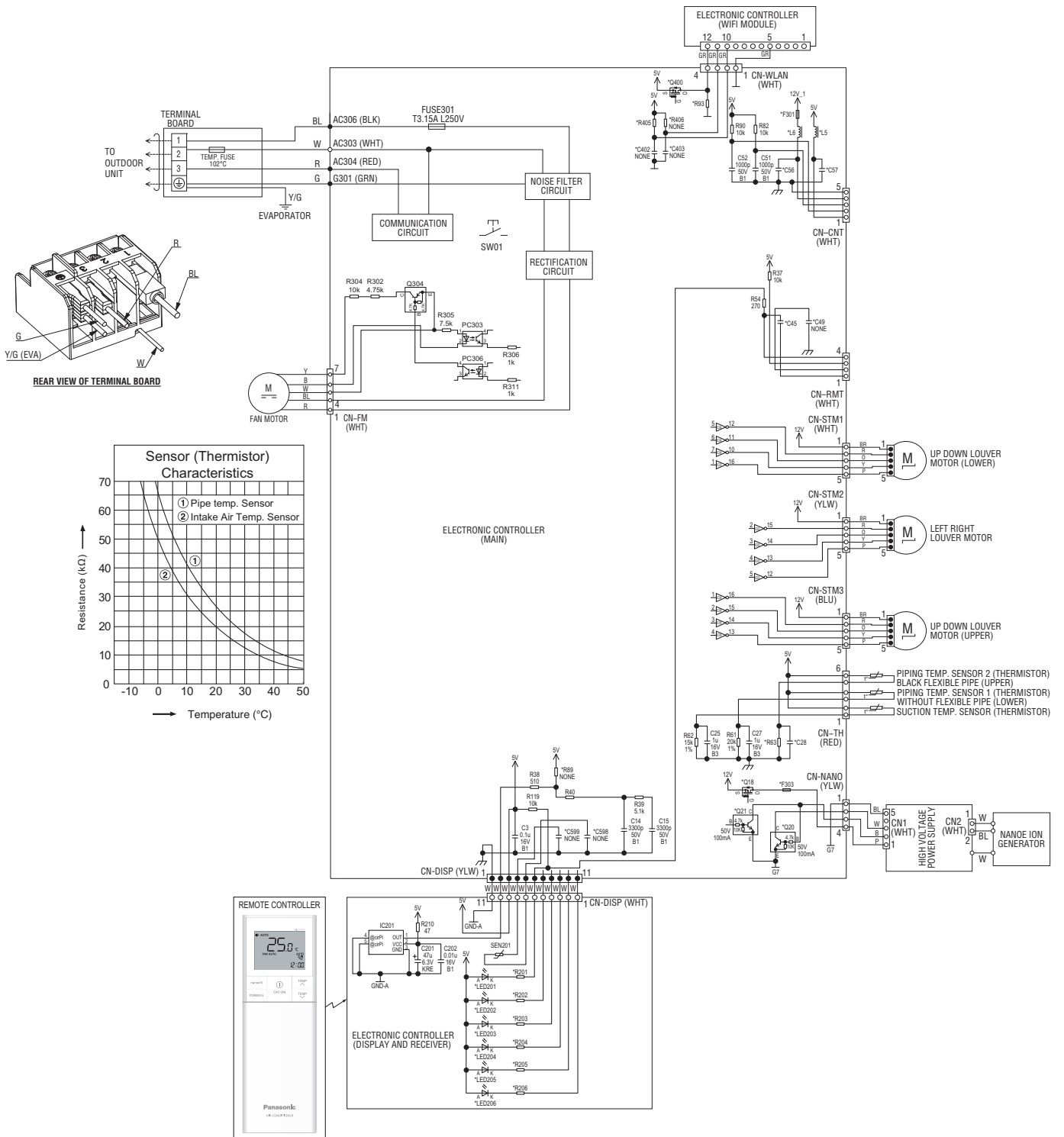

10.2 CS-MTZ16ZKE

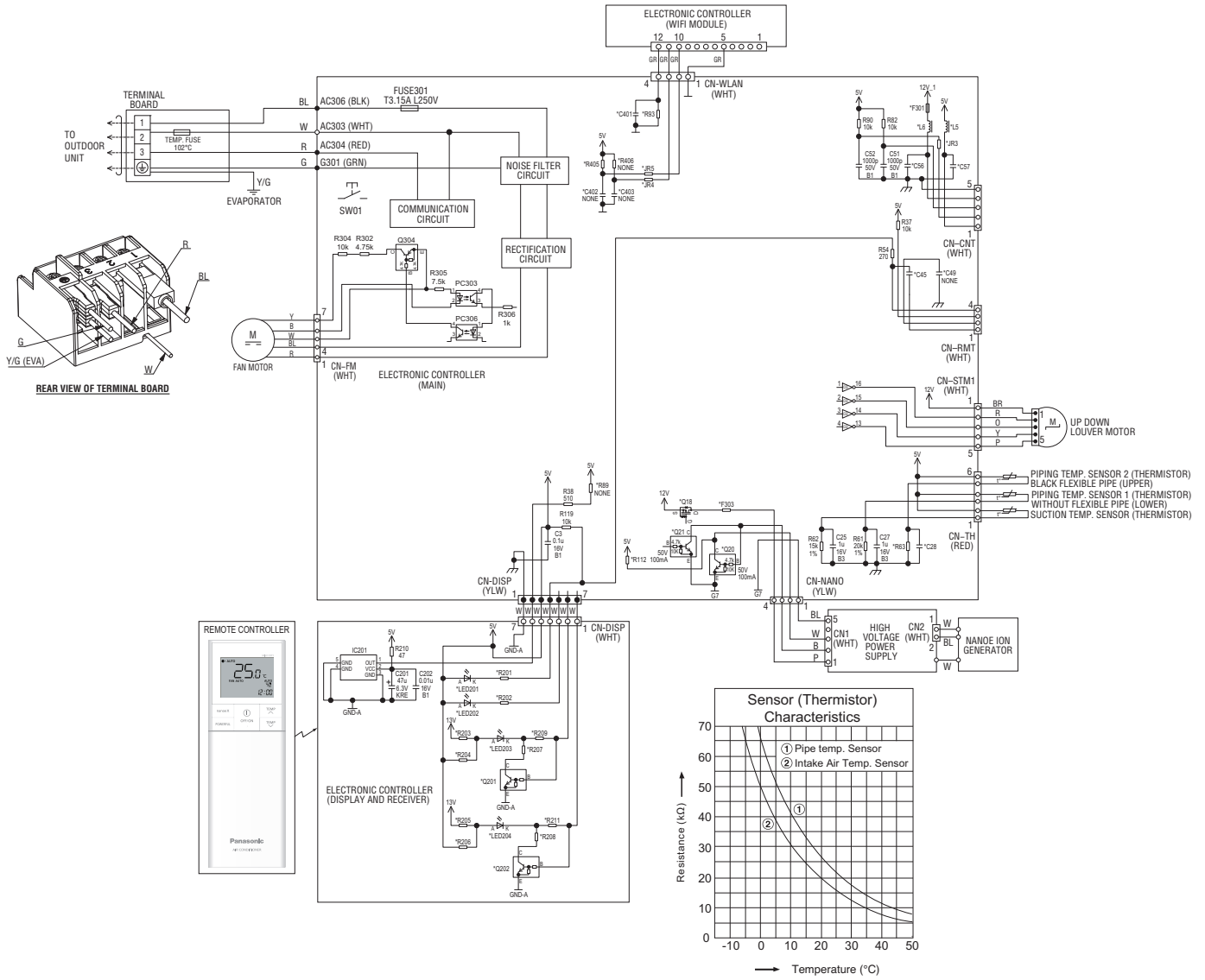

11. Printed Circuit Board

11.1 Indoor Unit

11.1.1 Main Printed Circuit Board

11.1.1.1 CS-MZ16ZKE

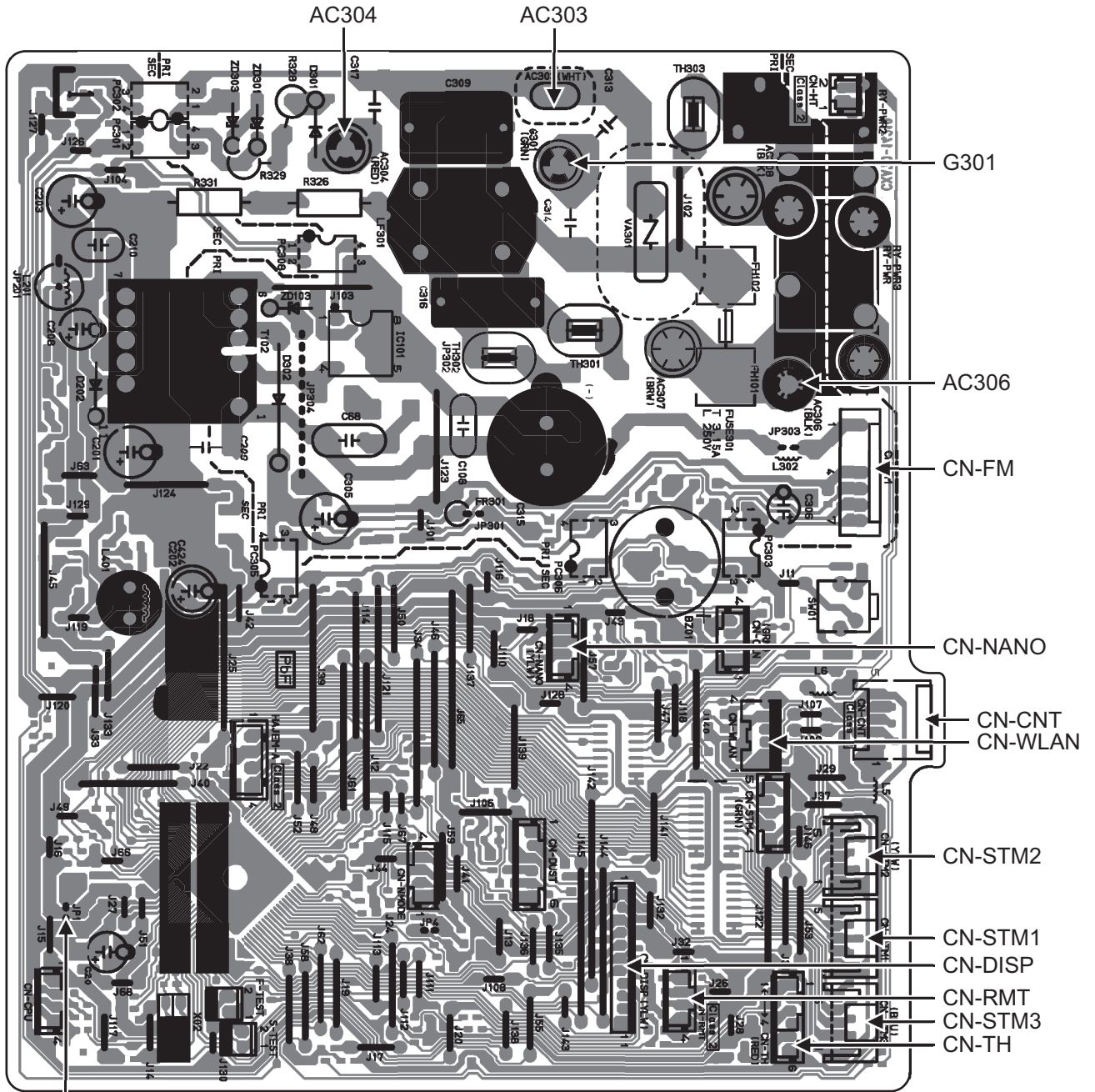

JP1 (Random Auto Restart enable/disable)

11.1.1.2 CS-MTZ16ZKE

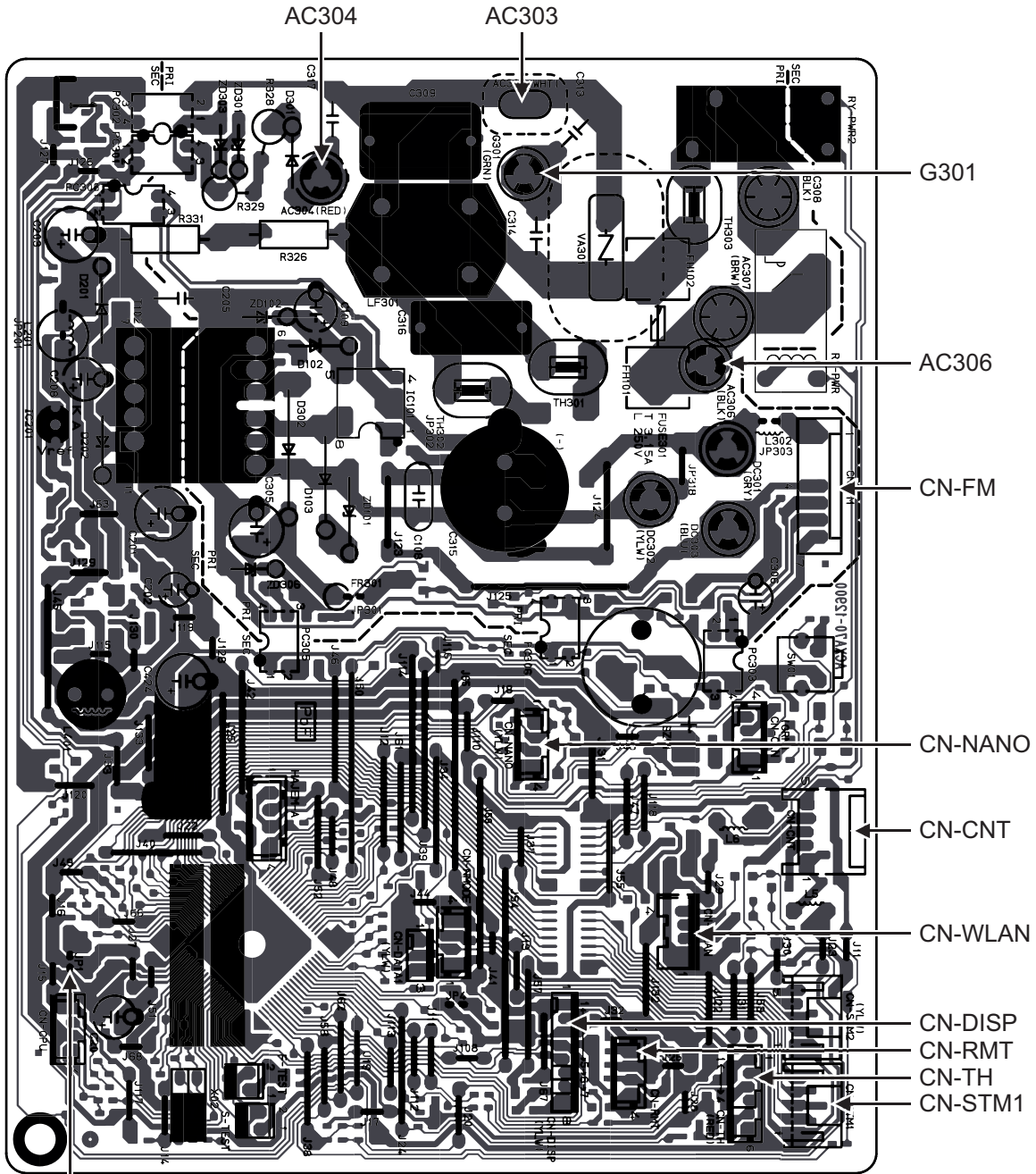

JP1 (Random Auto Restart enable/disable)

11.1.2 Indicator Printed Circuit Board

11.1.2.1 CS-MZ16ZKE

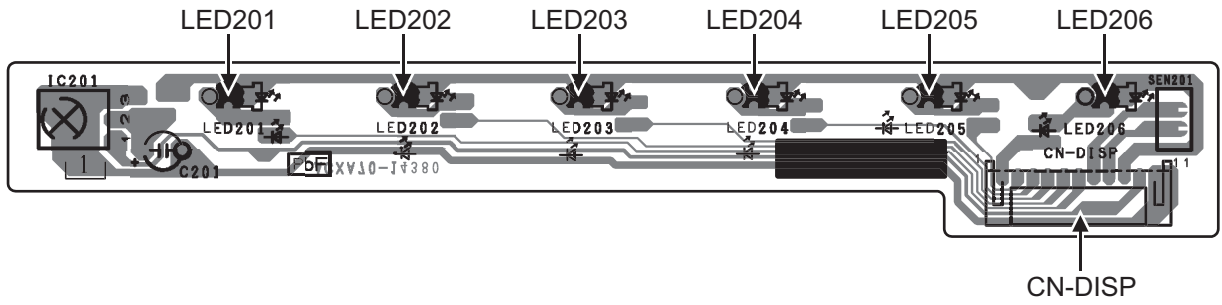

11.1.2.2 CS-MTZ16ZKE

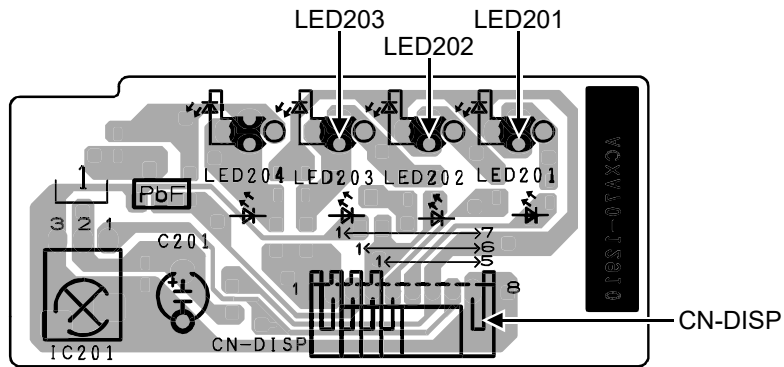

11.1.3 nanoe™X Printed Circuit Board

11.1.3.1 CS-MZ16ZKE

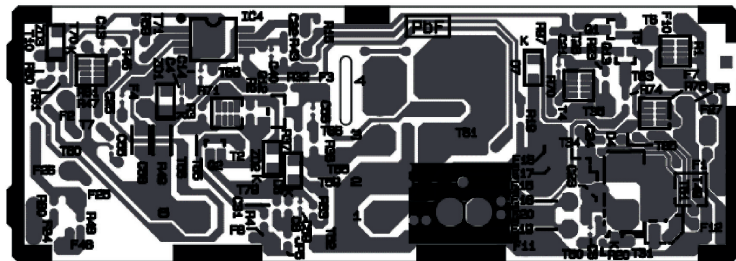

11.1.3.2 CS-MTZ16ZKE

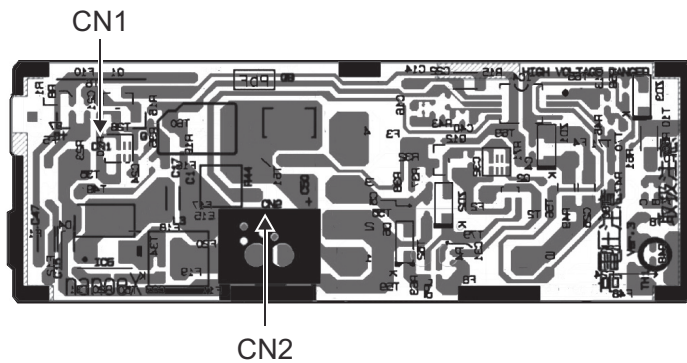

11.1.4 Wireless LAN Module Printed Circuit Board (Network Adapter)

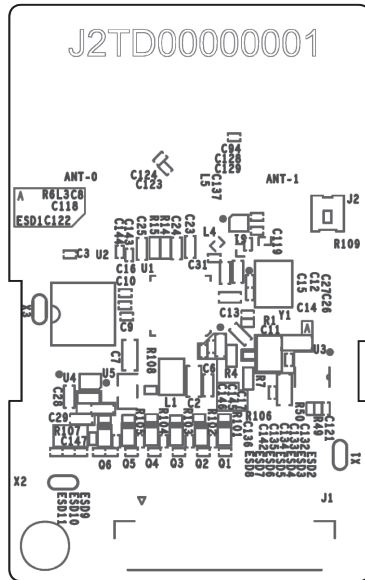

12. Installation Instruction

CS-MZ16ZKE

12.1 Select the Best Location

12.1.1 Indoor Unit

- Do not install the unit in excessive oil fume area such as kitchen, workshop and etc.
- There should not be any heat source or steam near the unit.
- There should not be any obstacles blocking the air circulation.
- A place where air circulation in the room is good.
- A place where drainage can be easily done.
- A place where noise prevention is taken into consideration.
- Do not install the unit near the door way.
- Ensure the spaces indicated by arrows from the wall, ceiling, fence or other obstacles.
- Indoor unit of this air conditioner shall be installed in a height of at least 1.8 m.

12.1.2 Indoor Unit Installation Diagram

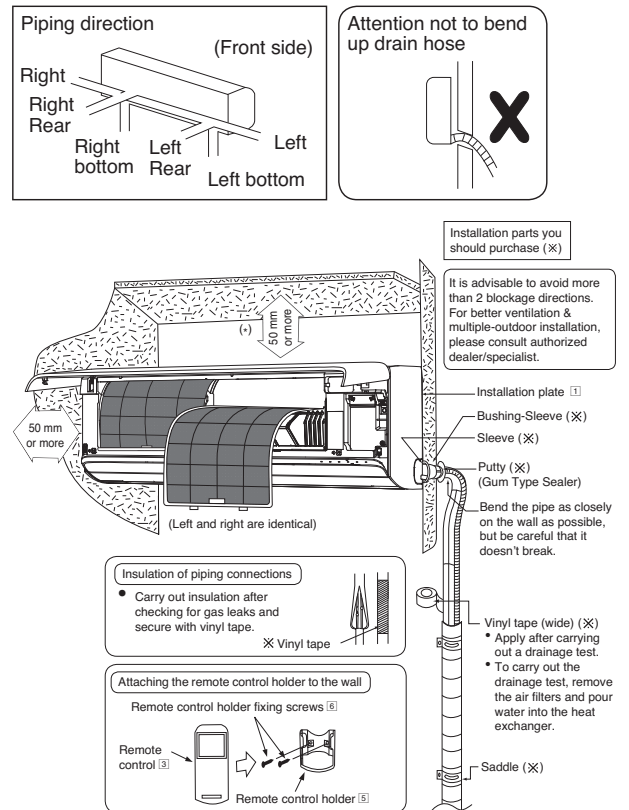

- This illustration is for explanation purposes only. The indoor unit will actually face a different way.
- (*) If holder at the rear of chassis (Refer column "12.2.3 Indoor Unit Installation") need to be used to prop up the unit, this distance shall be 65 mm or more.

12.2 Indoor Unit

12.2.1 How to Fix Installation Plate

The mounting wall shall be strong and solid enough to prevent it from vibration.

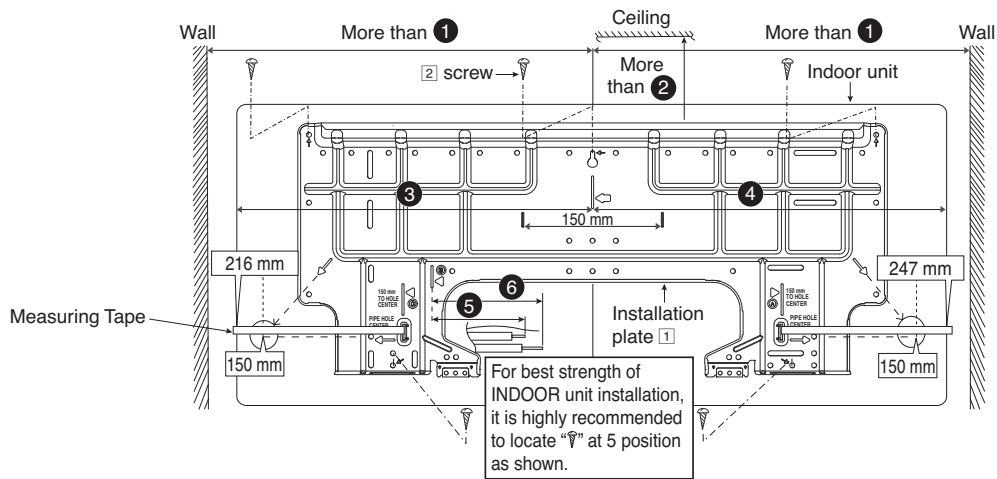

Model	Dimension					
	①	②	③	④	⑤	⑥
MZ16***	500 mm	70 mm (*)	420 mm	450 mm	113 mm	165 mm

The center of installation plate should be at more than ① at right and left of the wall.

The distance from installation plate edge to ceiling should be more than ②.

From installation plate center to unit's left side is ③.

From installation plate center to unit's right side is ④.

Ⓑ : For left side piping, piping connection for liquid should be about ⑤ from this line.

: For left side piping, piping connection for gas should be about ⑥ from this line.

Dimension ②
 (*) :-
 If holder at the rear of chassis (Refer column "12.2.3 Indoor Unit Installation") need to be used to prop up the unit, this distance shall be 85 mm or more.

- Mount the installation plate on the wall with 5 screws or more (at least 5 screws).
 (If mounting the unit on the concrete wall, consider using anchor bolts.)
 - Always mount the installation plate horizontally by aligning the marking-off line with the thread and using a level gauge.
- Drill the piping plate hole with $\varnothing 70$ mm hole-core drill.
 - Line according to the left and right side of the installation plate.
 The meeting point of the extended line is the center of the hole.
 Another method is by putting measuring tape at position as shown in the diagram above.
 The hole center is obtained by measuring the distance namely 150 mm for left and right hole respectively.
 - Drill the piping hole at either the right or the left and the hole should be slightly slanting to the outdoor side.

12.2.2 To Drill a Hole in the Wall and Install a Sleeve of Piping

- Insert the piping sleeve to the hole.
- Fix the bushing to the sleeve.
- Cut the sleeve until it extrudes about 15 mm from the wall.

CAUTION
 ⚠ When the wall is hollow, please be sure to use the sleeve for tube assembly to prevent dangers caused by mice biting the connection cable.

- Finish by sealing the sleeve with putty or caulking compound at the final stage.

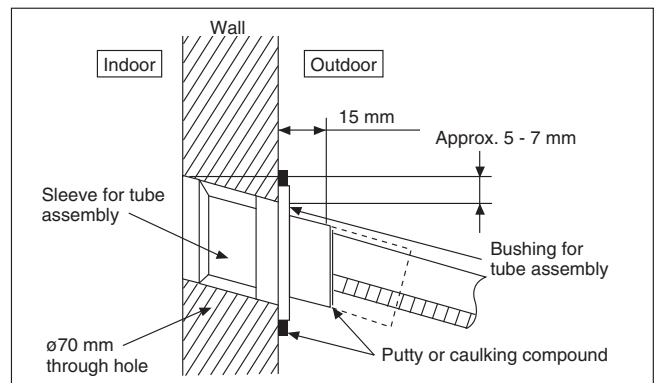

12.2.3 Indoor Unit Installation

Pull out the Indoor piping

- Do not turn over the unit without shock absorber during pull out the piping. It may cause intake grille damage.
- Use shock absorber during pull out the piping to protect the intake grille from damage.

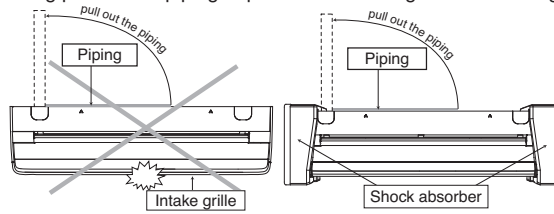

12.2.3.1 For the Right Rear Piping

- Step-1** Pull out the Indoor piping
- Step-2** Install the Indoor Unit
- Step-3** Secure the Indoor Unit
- Step-4** Insert the connection cable

12.2.3.2 For the Right and Right Bottom Piping

- Step-1** Pull out the Indoor piping
- Step-2** Install the Indoor Unit
- Step-3** Insert the connection cable
- Step-4** Secure the Indoor Unit

12.2.3.3 For the Embedded Piping

- Step-1** Change the drain hose position
- Step-2** Bend the embedded piping
 - Use a spring bender or equivalent to bend the piping so that the piping is not crushed.
- Step-3** Pull the connection cable into Indoor Unit
 - The inside and outside connection cable can be connected without removing the front grille.
- Step-4** Cut and flare the embedded piping
 - When determining the dimensions of the piping, slide the unit all the way to the left on the installation plate.
 - Refer to the column "Cutting and flaring the piping".
- Step-5** Install the Indoor Unit
- Step-6** Connect the piping
 - Please refer to "Connecting the piping" column in outdoor unit section. (Below steps are done after connecting the outdoor piping and gas-leakage confirmation.)
- Step-7** Insulate and finish the piping
 - Please refer to "Insulation of piping connection" column as mentioned in indoor/outdoor unit installation.
- Step-8** Secure the Indoor Unit

- Fasten the chassis to the installation plate with screws (Self purchase, Screw size: M4, max. length 10mm) to provide a neat appearance of indoor unit.

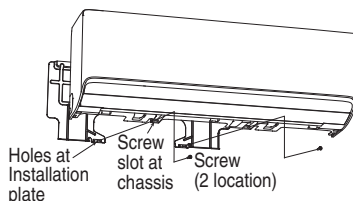

Right Rear piping

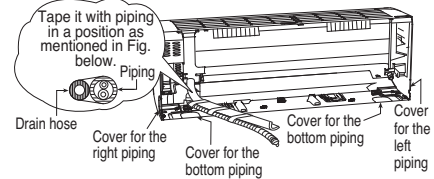

How to keep the cover

In case of the cover is cut, keep the cover at the rear of chassis as shown in the illustration for future reinstallation.

(Left, right and 2 bottom covers for piping.)

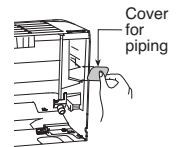

Right and Right bottom piping

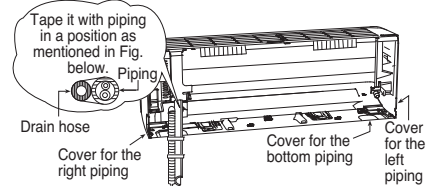

Install the indoor unit

Hook the indoor unit onto the upper portion of installation plate. (Engage the indoor unit with the upper edge of the installation plate) by moving it in left and right.

There is an option to use the holder at the rear of chassis to prop up the indoor unit as shown in the illustration for ease of installation. Push the holder back to original position before secure the indoor unit.

Alternatively, bottom plate of the indoor unit can be removed to enlarge the space for installation. Please refer column "How to take out front grille".

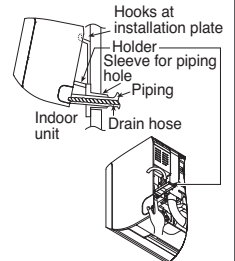

- Press the area of orange color to release holder.

Secure the Indoor Unit

Press the lower left and right side of the unit against the installation plate until hooks engages with their slot (sound click).

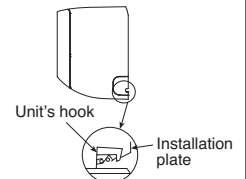

Insert the connection cable

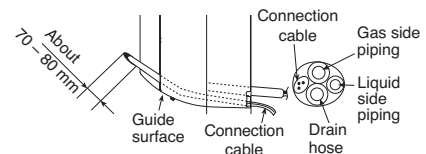

To take out the unit, push the ▽ marking at the bottom unit, and pull it slightly towards you to disengage the hooks from the unit.

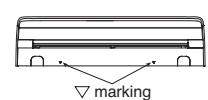

(This can be used for left rear piping also.)

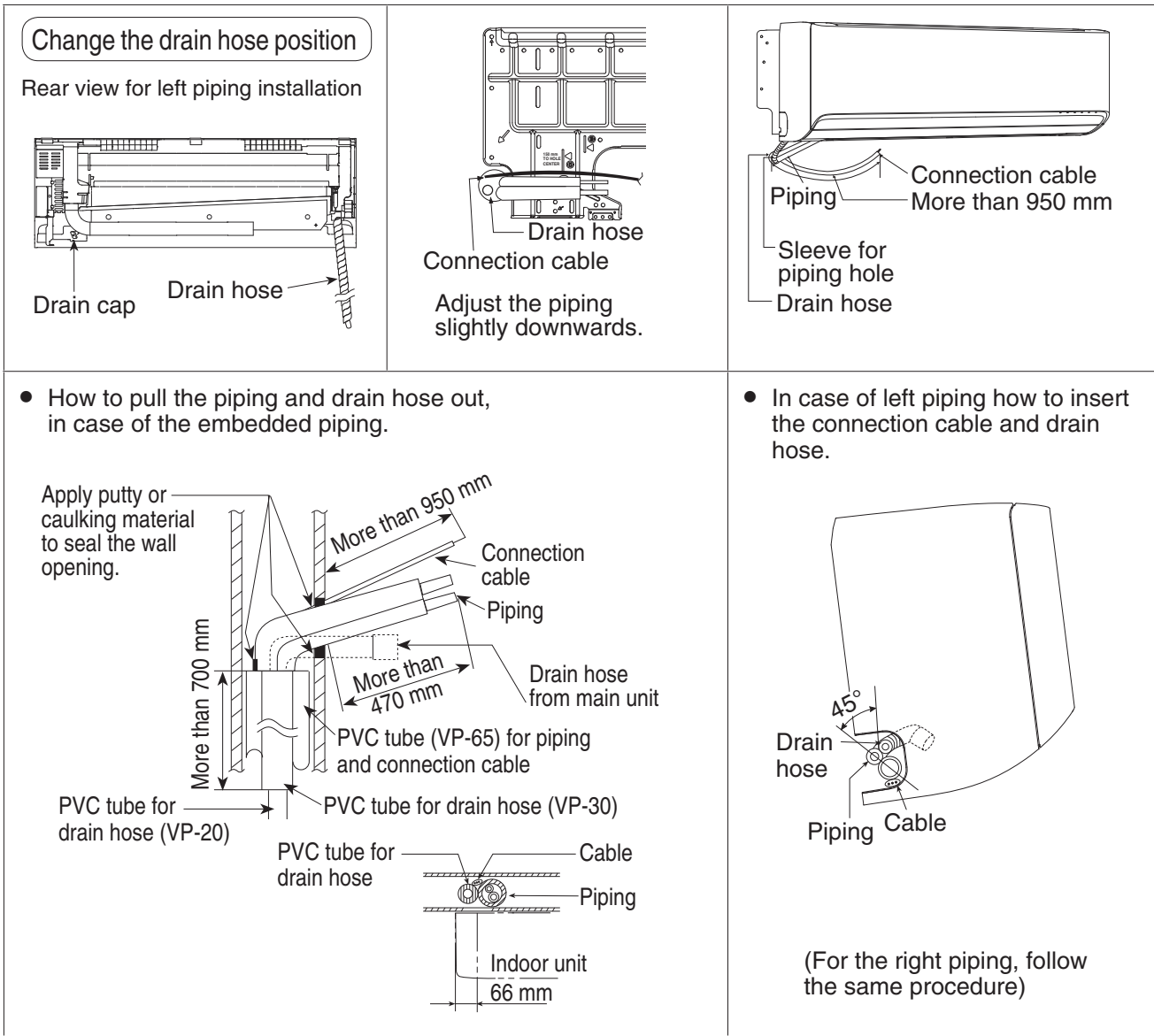

12.2.4 Connect the Cable to the Indoor Unit

- The inside and outside connection cable can be connected without removing the front grille.
- Connection cable** between indoor unit and outdoor unit shall be approved polychloroprene sheathed 4 x 1.5 mm² flexible cord, type designation 60245 IEC 57 or heavier cord. Do not use joint connection cable. Replace the wire if the existing wire (from concealed wiring, or otherwise) is too short. Allowable connection cable length of each indoor unit shall be 30 mm or less.
- Bind all the indoor and outdoor connection cable with tape and route the connection cable via the left side escapement.
- Remove the tapes and connect the connection cable between indoor unit and outdoor unit according to the diagram below.

Terminals on the indoor unit	1	2	3	
Colour of wires				
Terminals on the outdoor unit	1	2	3	

- Secure firmly the connection cable onto the control board with the holder. Do not overtighten holder screw, as this may damage the holder.

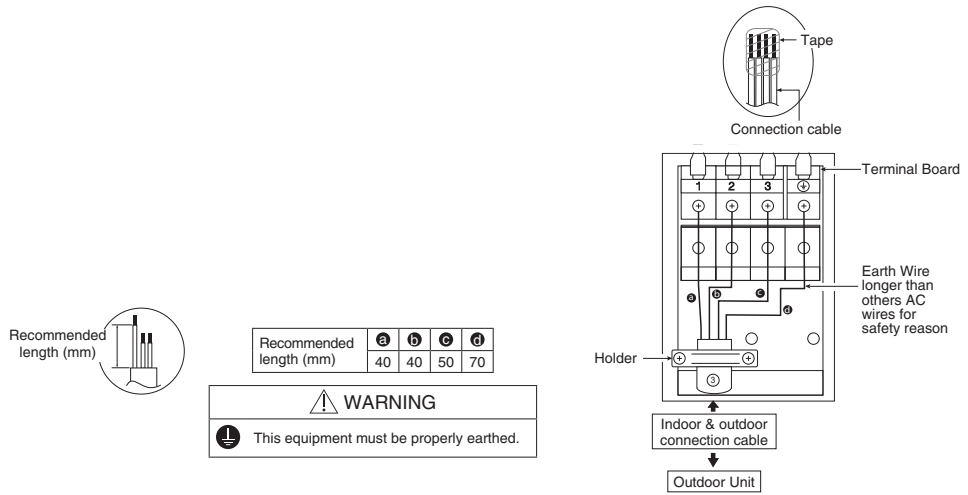

Note:

- Ensure the colour of wires of outdoor unit and the terminal Nos. are the same to the indoor's respectively.
- Earth wire shall be Yellow/Green (Y/G) in colour and longer than other AC wires for safety reason.

12.2.4.1 Wire Stripping and Connection Requirement

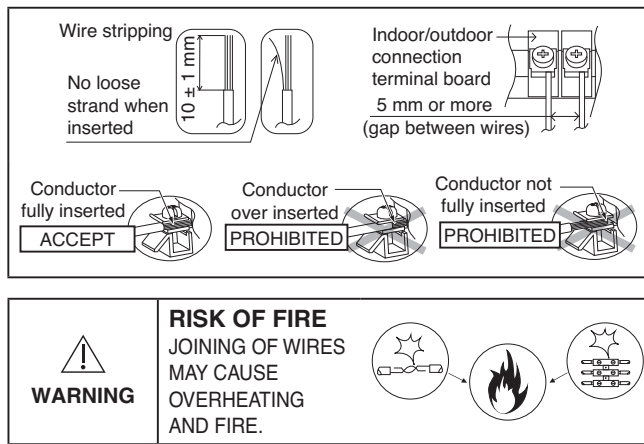

⊘ Do not joint wires.

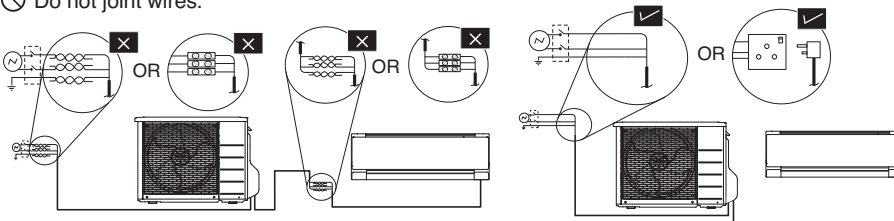

- ❗ Use complete wire without joining.
- ❗ Use approved socket and plug with earth pin.
- ❗ Wire connection in this area must follow to national wiring rules.

12.2.5 Connect the Piping

12.2.5.1 Connecting the Piping to Indoor

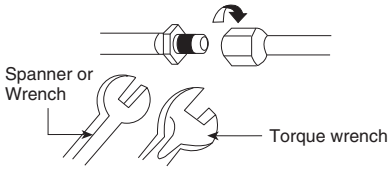
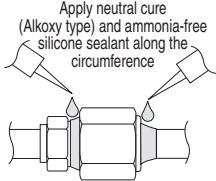
<p>For connection joint of all model</p> <p>Please make flare after inserting flare nut (locate at joint portion of tube assembly) onto the copper pipe. (In case of using long piping)</p> <p>Connect the piping</p> <ul style="list-style-type: none"> Align the center of piping and sufficiently tighten the flare nut with fingers. Further tighten the flare nut with torque wrench in specified torque as stated in the table. 	<p>Additional Precautions For R32 Models when connecting by flaring at indoor side</p> <div style="border: 1px solid black; padding: 5px; margin-bottom: 10px;"> <p>! Ensure to do the re-flaring of pipes before connecting to units to avoid leaking.</p> </div> <p>Seal sufficiently the flare nut (both gas and liquid sides) with neutral cure (Alkoxy type) & ammonia-free silicone sealant and insulation material to avoid the gas leak caused by freezing.</p>  <p>Neutral cure (Alkoxy type) & ammonia-free silicone sealant is only to be applied after pressure testing and cleaning up by following instructions of sealant, only to the outside of the connection. The aim is to prevent moisture from entering the connection joint and possible occurrence of freezing. Curing sealant will take some time. Make sure sealant will not peel off when wrapping the insulation.</p>
---	--

12.2.5.2 Connecting the Piping to Outdoor

Decide piping length and then cut by using pipe cutter. Remove burrs from cut edge. Make flare after inserting the flare nut (locate at valve) onto the copper pipe. Align center of piping to valve and then tighten with torque wrench to the specified torque as stated in the table.

<p>⊘ Do not overtighten, overtightening may cause gas leakage.</p>	
Piping size	Torque
6.35 mm (1/4")	[18 N•m (1.8 kgf•m)]
9.52 mm (3/8")	[42 N•m (4.3 kgf•m)]
12.7 mm (1/2")	[55 N•m (5.6 kgf•m)]
15.88 mm (5/8")	[65 N•m (6.6 kgf•m)]
19.05 mm (3/4")	[100 N•m (10.2 kgf•m)]

12.2.5.3 Cutting and Flaring the Piping

- Please cut using pipe cutter and then remove the burrs.
- Remove the burrs by using reamer. If burrs is not removed, gas leakage may be caused. Turn the piping end down to avoid the metal powder entering the pipe.
- Please make flare after inserting the flare nut onto the copper pipes.

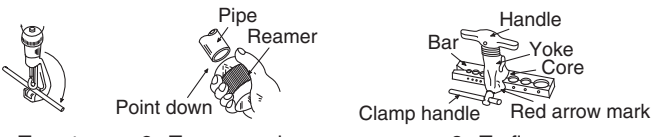

1. To cut

2. To remove burrs

3. To flare

■ Improper flaring ■

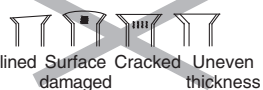

Inclined Surface Cracked Uneven thickness
damaged

When properly flared, the internal surface of the flare will evenly shine and be of even thickness. Since the flare part comes into contact with the connections, carefully check the flare finish.

12.2.6 How to Take Out Front Grille

Please follow the steps below to take out front grille if necessary such as when installing or servicing.

- 1 Pull down 3 caps at the bottom, then remove 3 mounting screws.
- 2 Cling finger around screw area slot, pull the bottom plate downward until a click sound indicates hook is unleashed.
Move the bottom plate forward carefully.
- 3 Open front panel.
- 4 Remove 3 mounting screws on the front grille.
- 5 Slide the 3 lock knobs on the upside of front grille to unlock position.
- 6 Set the upper vane to horizontal position.
Set the lower vane to slightly below horizontal position.
- 7 Pull the front grille towards you to remove the front grille.

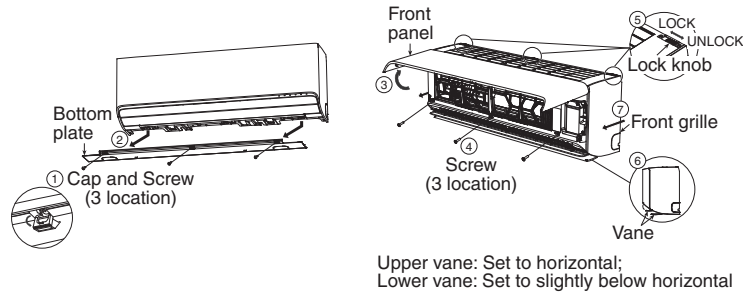



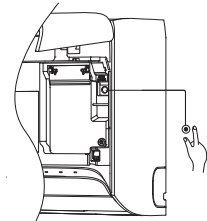

12.2.7 Auto Switch Operation

The below operations will be performed by pressing the "AUTO" switch.

- 1 **AUTO OPERATION MODE**
The Auto operation will be activated immediately once the Auto Switch is pressed and release within 5 sec..
- 2 **TEST RUN OPERATION (FOR PUMP DOWN/SERVICING PURPOSE)**
The Test Run operation will be activated if the Auto Switch is pressed continuously for more than 5 sec. to below 8 sec..
A "pep" sound will occur at the fifth sec., in order to identify the starting of Test Run operation.
- 3 **HEATING TRIAL OPERATION**
Press the "AUTO" switch continuously for more than 8 sec. to below 11 sec. and release when a "pep pep" sound is occurred at eight sec. (However, a "pep" sound is occurred at fifth sec..) Then press Remote controller "AC Reset" button once.
Remote controller signal will activate operation to force heating mode.
- 4 **REMOTE CONTROLLER RECEIVING SOUND ON/OFF**
The ON/OFF of Remote controller receiving sound can be change over by the following steps:
 - a) Press "AUTO" switch continuously for more than 16 sec. to below 21 sec..
A "pep", "pep", "pep", "pep" sound will occur at the sixteenth sec..
 - b) Press the "AC Reset" button once, "pep" sound will occur indicates that Remote controller receiving sound setting mode is activated.
 - c) Press "AUTO" switch again. Everytime "AUTO" switch is pressed (within 60 sec. interval), Remote controller receiving sound status will be reversed between ON and OFF.
Long "peep" sound indicates that Remote controller receiving sound is ON.
Short "pep" sound indicates that Remote controller receiving sound is OFF.



12.2.8 Heating Only Operation

- 1 Use remote controller to set heating only operation. When the unit in standby mode, follow the steps below:
 - a) Press  continuously for more than 5 seconds to enter special setting mode.
 - b) Press  to choose function 61, and then press  to set "01".
 - c) Press  to activate "Heating only operation".

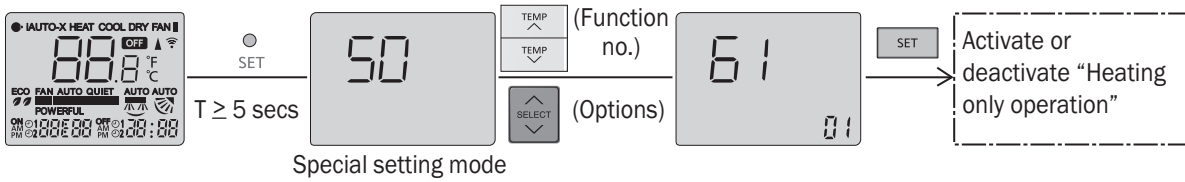

12.2.9 How to Replace Network Adapter

- Remove the front grille (refer how to take out front grille) from the unit.
- Remove the indicator piece by releasing the hook.
- Remove 1 mounting screw, then remove the network adaptor holder.
- After that, network adaptor can be easily replaced.

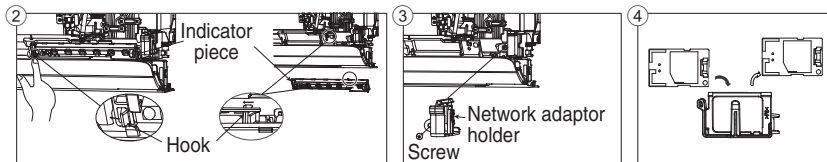

12.2.10 Check the Drainage

- Open front panel and remove air filters.
(Drainage checking can be carried out without removing the front grille.)
- Pour a glass of water into the drain tray-styrofoam.
- Ensure that water flows out from drain hose of the indoor unit.

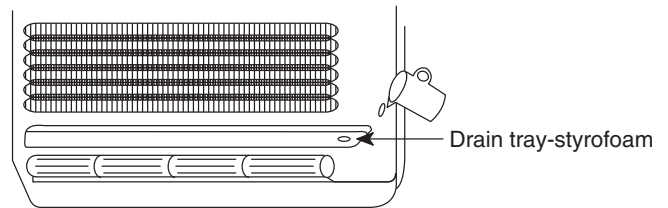

12.2.11 Evaluation of the Performance

- Operate the unit at cooling/heating operation mode for fifteen minutes or more.
- Measure the temperature of the intake and discharge air.
- Ensure the difference between the intake temperature and the discharge is more than 8°C during Cooling operation or more than 14°C during Heating operation.

Note:

- During extremely cold winter, turn on the power supply and standby the unit for at least 15 minutes before test run. Allow sufficient time to warm up refrigerant and prevent wrong error code judgement.

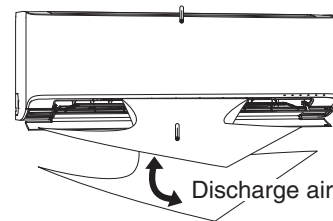

13. Installation Instruction

CS-MTZ16ZKE

13.1 Select the Best Location

13.1.1 Indoor Unit

- Do not install the unit in excessive oil fume area such as kitchen, workshop and etc.
- There should not be any heat source or steam near the unit.
- There should not be any obstacles blocking the air circulation.
- A place where air circulation in the room is good.
- A place where drainage can be easily done.
- A place where noise prevention is taken into consideration.
- Do not install the unit near the door way.
- Ensure the spaces indicated by arrows from the wall, ceiling, fence or other obstacles.
- Indoor unit of this air conditioner shall be installed in a height of at least 1.8 m.

13.1.2 Indoor Unit Installation Diagram

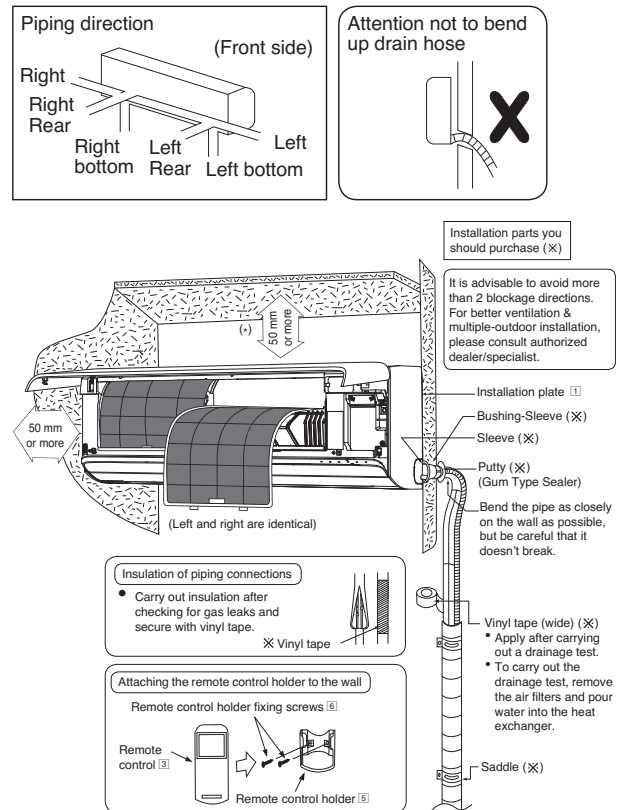

- This illustration is for explanation purposes only. The indoor unit will actually face a different way.
- (*) If holder at the rear of chassis (Refer column "13.2.3 Indoor Unit Installation") need to be used to prop up the unit, this distance shall be 65 mm or more.

13.2 Indoor Unit

13.2.1 How to Fix Installation Plate

The mounting wall shall be strong and solid enough to prevent it from vibration.

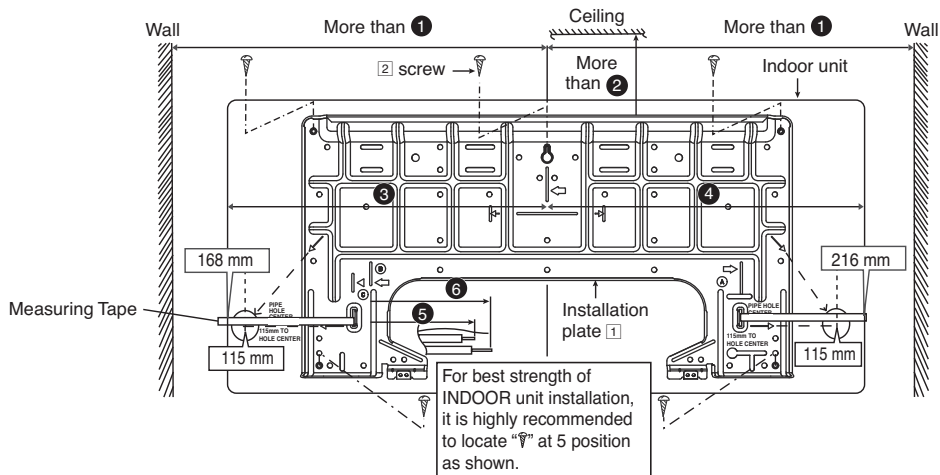

Model	Dimension					
	1	2	3	4	5	6
MTZ16***	465 mm	70 mm (*)	365 mm	415 mm	60 mm	120 mm

The center of installation plate should be at more than ① at right and left of the wall.

The distance from installation plate edge to ceiling should be more than ②.

From installation plate center to unit's left side is ③.

From installation plate center to unit's right side is ④.

- Ⓑ : For left side piping, piping connection for liquid should be about ⑤ from this line.
 : For left side piping, piping connection for gas should be about ⑥ from this line.

Dimension ②
 (*) :-
 If holder at the rear of chassis (Refer column "13.2.3 Indoor Unit Installation") need to be used to prop up the unit, this distance shall be 85 mm or more.

- Mount the installation plate on the wall with 5 screws or more (at least 5 screws).
 (If mounting the unit on the concrete wall, consider using anchor bolts.)
 - Always mount the installation plate horizontally by aligning the marking-off line with the thread and using a level gauge.
- Drill the piping plate hole with $\varnothing 70$ mm hole-core drill.
 - Line according to the left and right side of the installation plate.
 The meeting point of the extended line is the center of the hole.
 Another method is by putting measuring tape at position as shown in the diagram above.
 The hole center is obtained by measuring the distance namely 115 mm for left and right hole respectively.
 - Drill the piping hole at either the right or the left and the hole should be slightly slanting to the outdoor side.

13.2.2 To Drill a Hole in the Wall and Install a Sleeve of Piping

- Insert the piping sleeve to the hole.
- Fix the bushing to the sleeve.
- Cut the sleeve until it extrudes about 15 mm from the wall.

CAUTION
 ⚠ When the wall is hollow, please be sure to use the sleeve for tube assembly to prevent dangers caused by mice biting the connection cable.

- Finish by sealing the sleeve with putty or caulking compound at the final stage.

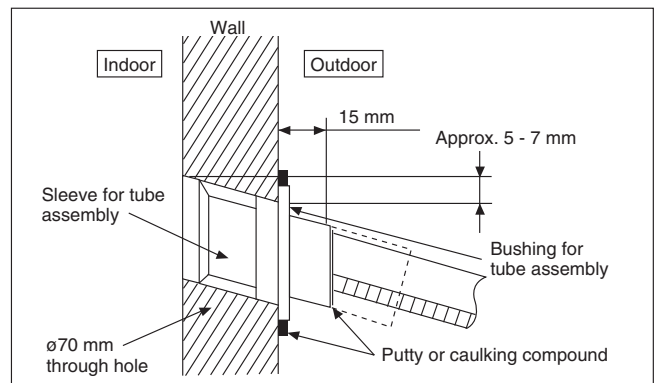

13.2.3 Indoor Unit Installation

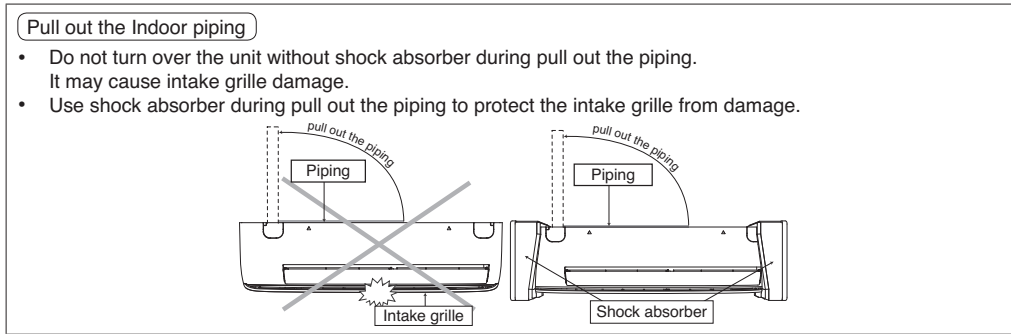

13.2.3.1 For the Right Rear Piping

- Step-1** Pull out the Indoor piping
- Step-2** Install the Indoor Unit
- Step-3** Secure the Indoor Unit
- Step-4** Insert the connection cable

13.2.3.2 For the Right and Right Bottom Piping

- Step-1** Pull out the Indoor piping
- Step-2** Install the Indoor Unit
- Step-3** Insert the connection cable
- Step-4** Secure the Indoor Unit

13.2.3.3 For the Embedded Piping

- Step-1** Change the drain hose position
- Step-2** Bend the embedded piping
 - Use a spring bender or equivalent to bend the piping so that the piping is not crushed.
- Step-3** Pull the connection cable into Indoor Unit
 - The inside and outside connection cable can be connected without removing the front grille.
- Step-4** Cut and flare the embedded piping
 - When determining the dimensions of the piping, slide the unit all the way to the left on the installation plate.
 - Refer to the column "Cutting and flaring the piping".
- Step-5** Install the Indoor Unit
- Step-6** Connect the piping
 - Please refer to "Connecting the piping" column in outdoor unit section. (Below steps are done after connecting the outdoor piping and gas-leakage confirmation.)
- Step-7** Insulate and finish the piping
 - Please refer to "Insulation of piping connection" column as mentioned in indoor/outdoor unit installation.
- Step-8** Secure the Indoor Unit

- Fasten the chassis to the installation plate with screws (Self purchase, Screw size: M4, max. length 10 mm) to provide a neat appearance of indoor unit. Please refer column "How to take out front grille" to remove the front grille.

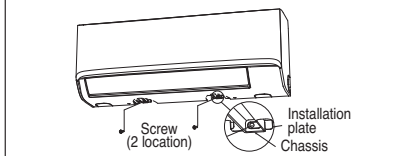

Right Rear piping

Tape it with piping in a position as mentioned in Fig. below.

Drain hose
Cover for the right piping
Cover for the bottom piping
Cover for the left piping

How to keep the cover

In case of the cover is cut, keep the cover at the rear of chassis as shown in the illustration for future reinstallation. (Left, right and 2 bottom covers for piping.)

Right and Right bottom piping

Tape it with piping in a position as mentioned in Fig. below.

Drain hose
Cover for the right piping
Cover for the bottom piping
Cover for the left piping

Install the indoor unit

Hook the indoor unit onto the upper portion of installation plate. (Engage the indoor unit with the upper edge of the installation plate). Ensure the hooks are properly seated on the installation plate by moving it in left and right.

Hooks at installation plate
Holder
Sleeve for piping hole
Piping
Indoor unit
Drain hose

In case of embedded piping, for model there is an option to use the holder at the rear of chassis to prop up the indoor unit as shown in the illustration for ease of installation. Push the holder back to original position before secure the indoor unit.

- Press the area of orange color to release holder.
- 1 holder.

Secure the Indoor Unit

Press the lower left and right side of the unit against the installation plate until hooks engages with their slot (sound click).

Unit's hook
Installation plate

Insert the connection cable

About 70-80mm
Guide surface
Connection cable
Gas side piping
Liquid side piping
Drain hose

To take out the unit, push the ▽ marking at the bottom unit, and pull it slightly towards you to disengage the hooks from the unit.

▽ marking

(This can be used for left rear piping also.)

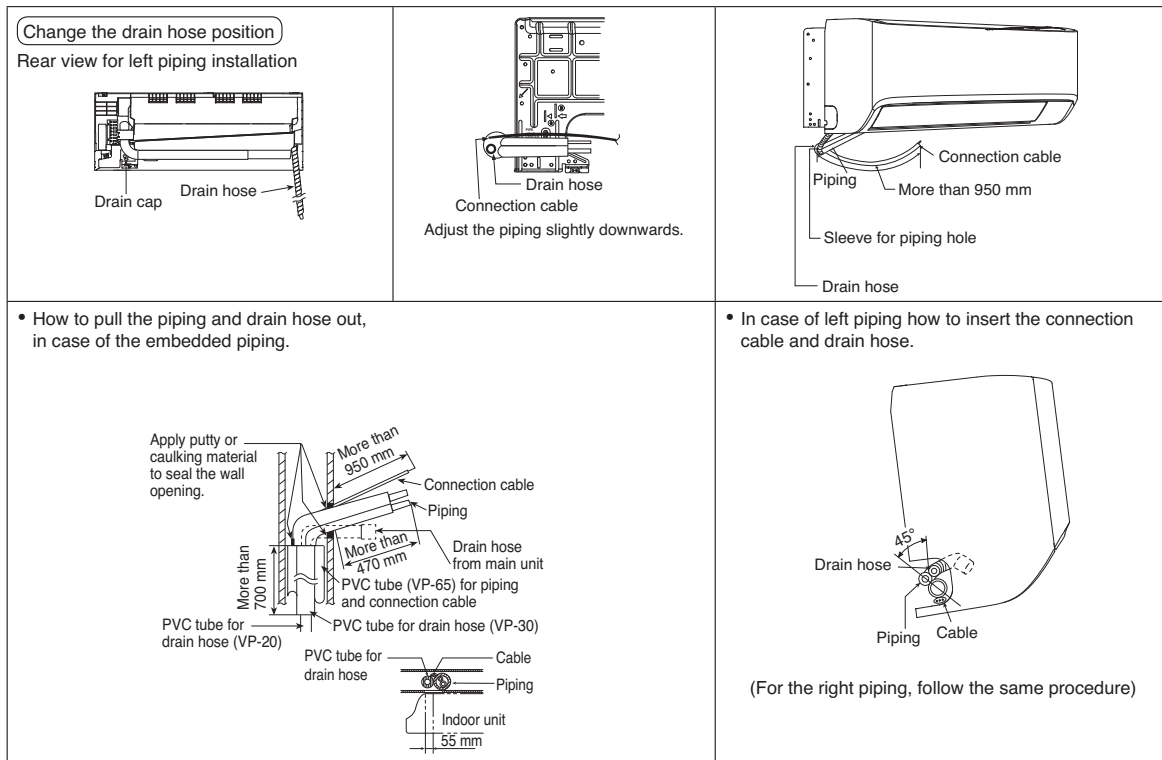

13.2.4 Connect the Cable to the Indoor Unit

- The inside and outside connection cable can be connected without removing the front grille.
- Connection cable** between indoor unit and outdoor unit shall be approved polychloroprene sheathed 4 x 1.5 mm² flexible cord, type designation 60245 IEC 57 or heavier cord. Do not use joint connection cable. Replace the wire if the existing wire (from concealed wiring, or otherwise) is too short. Allowable connection cable length of each indoor unit shall be 30 mm or less.
- Bind all the indoor and outdoor connection cable with tape and route the connection cable via the left side escapement.
- Remove the tapes and connect the connection cable between indoor unit and outdoor unit according to the diagram below.

Terminals on the indoor unit	1	2	3	
Colour of wires				
Terminals on the outdoor unit	1	2	3	

- Secure firmly the connection cable onto the control board with the holder. Do not overtighten holder screw, as this may damage the holder.

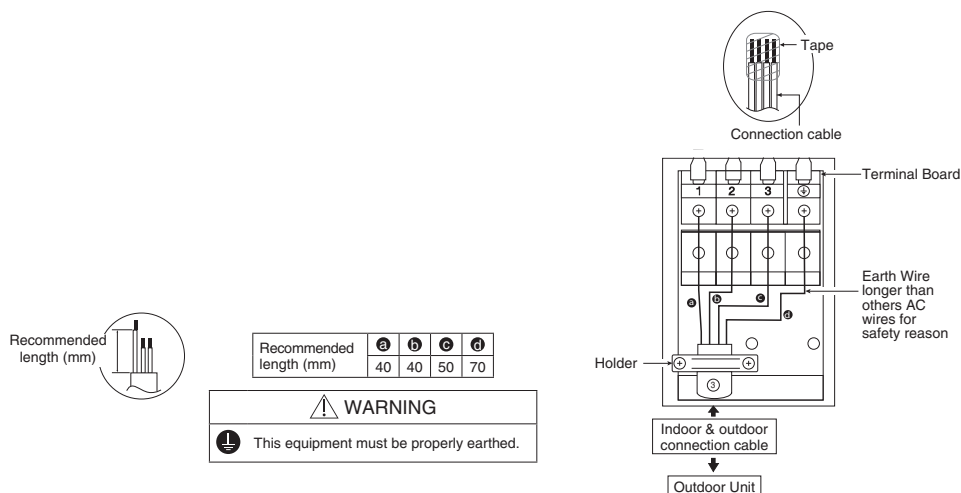

- Note:
- Ensure the colour of wires of outdoor unit and the terminal Nos. are the same to the indoor's respectively.
 - Earth wire shall be Yellow/Green (Y/G) in colour and longer than other AC wires for safety reason.

13.2.4.1 Wire Stripping and Connection Requirement

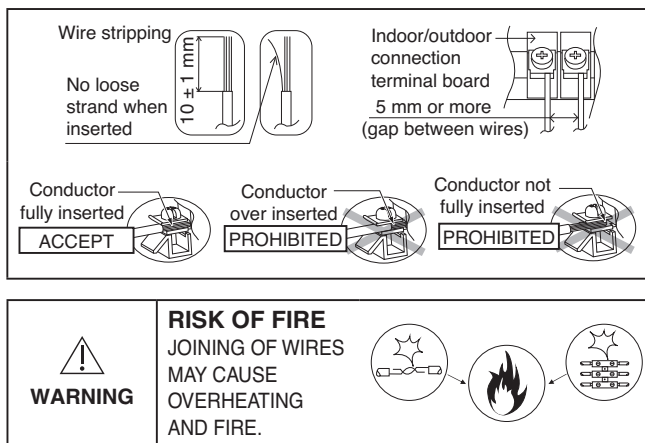

⊘ Do not joint wires.

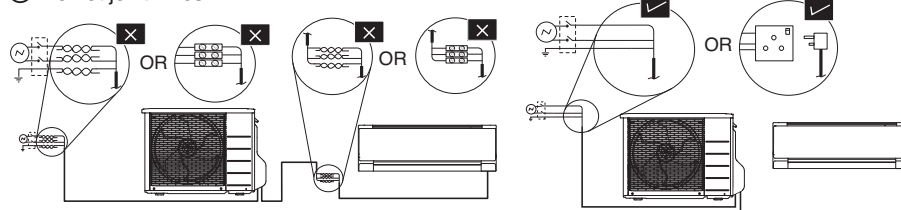

- ❗ Use complete wire without joining.
- ❗ Use approved socket and plug with earth pin.
- ❗ Wire connection in this area must follow to national wiring rules.

13.2.5 Connect the Piping

13.2.5.1 Connecting the Piping to Indoor

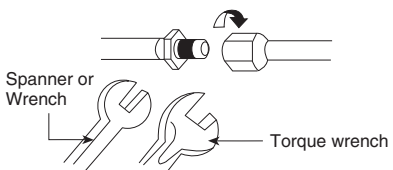
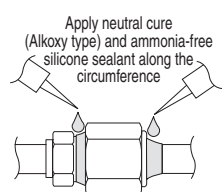
<p>For connection joint of all model</p> <p>Please make flare after inserting flare nut (locate at joint portion of tube assembly) onto the copper pipe. (In case of using long piping)</p> <p>Connect the piping</p> <ul style="list-style-type: none"> ● Align the center of piping and sufficiently tighten the flare nut with fingers. ● Further tighten the flare nut with torque wrench in specified torque as stated in the table. 	<p>Additional Precautions For R32 Models when connecting by flaring at indoor side</p> <div style="border: 1px solid black; padding: 5px; margin-bottom: 10px;"> <p>❗ Ensure to do the re-flaring of pipes before connecting to units to avoid leaking.</p> </div> <p>Seal sufficiently the flare nut (both gas and liquid sides) with neutral cure (Alkoxy type) & ammonia-free silicone sealant and insulation material to avoid the gas leak caused by freezing.</p>  <p>Neutral cure (Alkoxy type) & ammonia-free silicone sealant is only to be applied after pressure testing and cleaning up by following instructions of sealant, only to the outside of the connection. The aim is to prevent moisture from entering the connection joint and possible occurrence of freezing. Curing sealant will take some time. Make sure sealant will not peel off when wrapping the insulation.</p>
---	---

13.2.5.2 Connecting the Piping to Outdoor

Decide piping length and then cut by using pipe cutter. Remove burrs from cut edge. Make flare after inserting the flare nut (locate at valve) onto the copper pipe. Align center of piping to valve and then tighten with torque wrench to the specified torque as stated in the table.

⊘ Do not overtighten, overtightening may cause gas leakage.

Piping size	Torque
6.35 mm (1/4")	[18 N•m (1.8 kgf•m)]
9.52 mm (3/8")	[42 N•m (4.3 kgf•m)]
12.7 mm (1/2")	[55 N•m (5.6 kgf•m)]
15.88 mm (5/8")	[65 N•m (6.6 kgf•m)]
19.05 mm (3/4")	[100 N•m (10.2 kgf•m)]

13.2.5.3 Cutting and Flaring the Piping

- 1 Please cut using pipe cutter and then remove the burrs.
- 2 Remove the burrs by using reamer. If burrs is not removed, gas leakage may be caused. Turn the piping end down to avoid the metal powder entering the pipe.
- 3 Please make flare after inserting the flare nut onto the copper pipes.

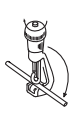

1. To cut

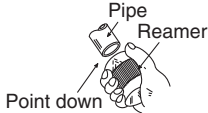

2. To remove burrs



3. To flare

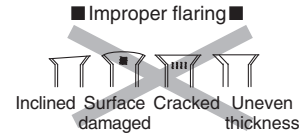
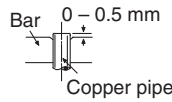

When properly flared, the internal surface of the flare will evenly shine and be of even thickness. Since the flare part comes into contact with the connections, carefully check the flare finish.

13.2.6 How to Take Out Front Grille

Please follow the steps below to take out front grille if necessary such as when installing or servicing.

- 1 Open front panel.
- 2 Remove the 3 mounting screws on the front grille as shown in the illustration below.
- 3 Slide the 3 lock knobs on the upside of front grille to unlock position.
- 4 Pull the front grille towards you to remove the front grille.

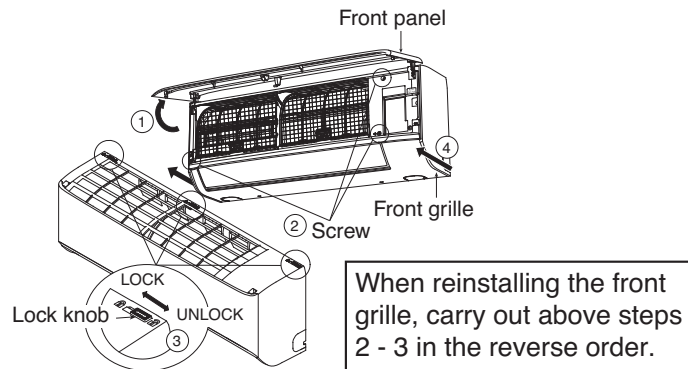

When reinstalling the front grille, carry out above steps 2 - 3 in the reverse order.



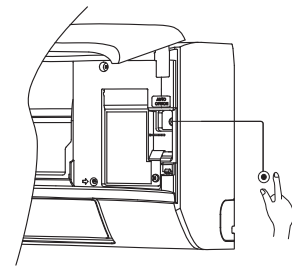

13.2.7 Auto Switch Operation

The below operations will be performed by pressing the "AUTO" switch.

- 1 **AUTO OPERATION MODE**
The Auto operation will be activated immediately once the Auto Switch is pressed and release within 5 sec..
- 2 **TEST RUN OPERATION (FOR PUMP DOWN/SERVICING PURPOSE)**
The Test Run operation will be activated if the Auto Switch is pressed continuously for more than 5 sec. to below 8 sec..
A "pep" sound will occur at the fifth sec., in order to identify the starting of Test Run operation.
- 3 **HEATING TRIAL OPERATION**
Press the "AUTO" switch continuously for more than 8 sec. to below 11 sec. and release when a "pep pep" sound is occurred at eight sec. (However, a "pep" sound is occurred at fifth sec..) Then press Remote controller "AC Reset" button once.
Remote controller signal will activate operation to force heating mode.
- 4 **REMOTE CONTROLLER RECEIVING SOUND ON/OFF**
The ON/OFF of Remote controller receiving sound can be change over by the following steps:
 - a) Press "AUTO" switch continuously for more than 16 sec. to below 21 sec..
A "pep", "pep", "pep", "pep" sound will occur at the sixteenth sec..
 - b) Press the "AC Reset" button once, "pep" sound will occur indicates that Remote controller receiving sound setting mode is activated.
 - c) Press "AUTO" switch again. Everytime "AUTO" switch is pressed (within 60 sec. interval), Remote controller receiving sound status will be reversed between ON and OFF.
Long "peep" sound indicates that Remote controller receiving sound is ON.
Short "pep" sound indicates that Remote controller receiving sound is OFF.



13.2.8 Heating Only Operation

- 1 Use remote controller to set heating only operation. When the unit in standby mode, follow the steps below:
 - a) Press  continuously for more than 5 seconds to enter special setting mode.
 - b) Press  to choose function 61, and then press  to set "01".
 - c) Press  to activate "Heating only operation".

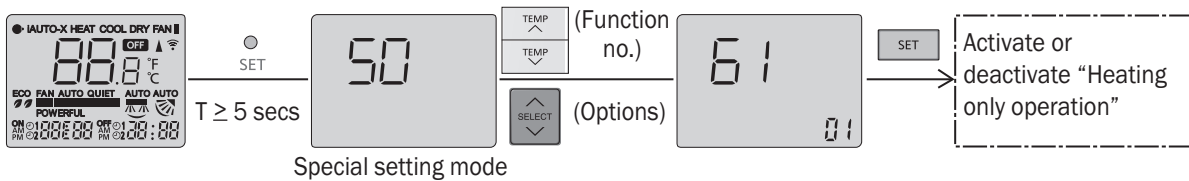

13.2.9 How to Replace Network Adapter

- 1 Remove the front grille (refer how to take out front grille) from the unit.
- 2 Unplug the wire.
- 3 After that, network adaptor can be easily replaced.

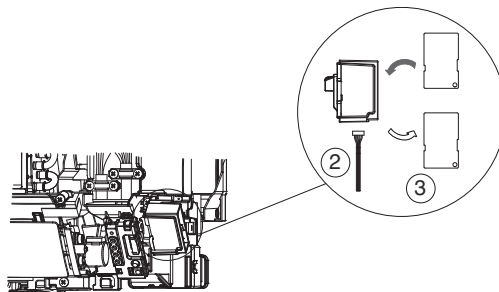

13.2.10 Check the Drainage

- Open front panel and remove air filters. (Drainage checking can be carried out without removing the front grille.)
- Pour a glass of water into the drain tray-styrofoam.
- Ensure that water flows out from drain hose of the indoor unit.

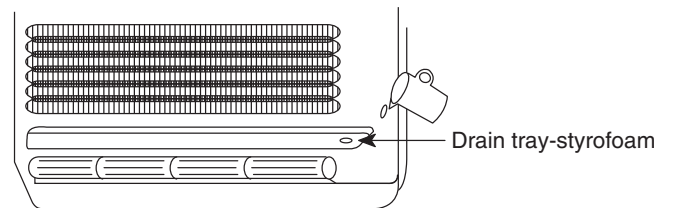

13.2.11 Evaluation of the Performance

- Operate the unit at cooling/heating operation mode for fifteen minutes or more.
- Measure the temperature of the intake and discharge air.
- Ensure the difference between the intake temperature and the discharge is more than 8°C during Cooling operation or more than 14°C during Heating operation.

Note:

- During extremely cold winter, turn on the power supply and standby the unit for at least 15 minutes before test run. Allow sufficient time to warm up refrigerant and prevent wrong error code judgement.

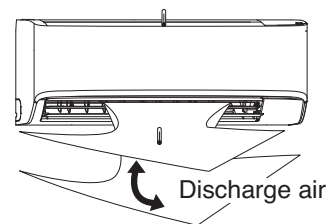

14. Operation Control (For Multi Split Connection)

During multi split connection, indoor unit's operation controls are same with single split connection unless specified in this chapter.

14.1 Cooling operation

14.1.1 Thermostat control

- Capability supply to indoor unit is OFF (Expansion valve closed) when Intake Air Temperature — Internal setting temperature $< -2.0^{\circ}\text{C}$.
- Capability resume supply to indoor unit after waiting for 3 minutes, if the Intake Air temperature — Internal setting temperature $>$ Capability supply OFF point.

14.2 Soft Dry Operation

14.2.1 Thermostat control

- Capability supply to indoor unit is OFF (Expansion valve closed) when Intake Air Temperature — Internal setting temperature $< -3.0^{\circ}\text{C}$.
- Capability resume to indoor unit after waiting for 3 minutes, if the Intake Air temperature — Internal setting temperature $>$ Capability supply OFF point.

14.3 Heating Operation

14.3.1 Thermostat control

- Capability supply to indoor unit is OFF (Expansion valve closed) when Intake Air Temperature — Internal setting temperature $> +1.0^{\circ}\text{C}$.
- During this condition, the indoor fan is stopped if compressor is ON.
- Capability resume supply to indoor unit after waiting for 3 minutes, if the Intake Air Temperature — Internal setting temperature $<$ Capability supply OFF point.

14.3.2 Temperature Sampling Control

- Temperature sampling is controlled by outdoor unit where room temperature for all power supply ON indoor unit could be obtained.
- When capability supply to the indoor unit is OFF and the compressor is ON, the indoor fan motor is stopped. During this condition, 15 seconds after sampling signal from outdoor unit is received, the indoor fan start operation at low fan speed.
- However, within first 4 minutes of capability stopped supply to the indoor unit, even sampling signal is received, the sampling control is cancelled.

14.4 Automatic Operation

- This mode can be set using remote control and the operation is decided by remote control setting temperature, remote control operation mode, indoor intake and outdoor air temperature.
- During operation mode judgment, indoor fan motor (with speed of -Lo) and outdoor fan motor are running for 30 seconds to detect the indoor intake and outdoor air temperature. The operation mode is decided based on below chart.

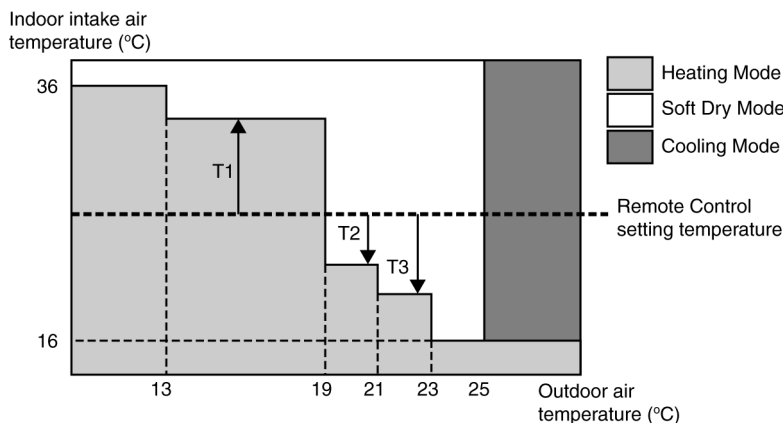

- Every 180 minutes, the indoor and outdoor temperature is judge. Based on remote control setting temperature, the value of T1 will increase up to 10°C, T2 will decrease by 3°C and T3 will decrease up to 8°C.

14.5 Indoor Fan Motor Operation

14.5.1 Residual Heat Removal Control

- To prevent high pressure at indoor unit, when heating mode thermostat-off condition or power supply OFF, indoor fan continue to operate at controlled fan speed for maximum 30 seconds then stop.

14.6 Powerful Mode Operation

- When the power mode is selected, the internal setting temperature will shift lower up to 4.0°C for Cooling/Soft Dry or higher up to 6.0°C for heating than remote control setting temperature, the powerful operation continue until user cancel the Powerful operation by pressing powerful button again.

14.7 Auto Restart Control

- When the power supply is cut off during the operation of air conditioner, the compressor will re-operate between three to four minutes (10 patterns to be selected randomly) after power resume.
- During multi split connection, Indoor unit will resume previous mode, include unit standby mode.

14.8 Indication Panel

LED	POWER	TIMER	nanoe X	📶
Color	White	White	White	White
Light ON	Operation ON	Timer Setting ON	nanoe ON	Wireless LAN Mode ON
Light OFF	Operation OFF	Timer Setting OFF	nanoe OFF	Wireless LAN Mode OFF

Note:

- If POWER LED is blinking (0.5 seconds ON, 0.5 second OFF), the possible operation of the unit are during Indoor Residual Heat Removal, Hot Start, during Deice operation, operation mode judgment, or ON timer sampling.
- If POWER LED is blinking (2.5 seconds ON, 0.5 second OFF), the unit is in standby mode.
- If TIMER LED is blinking, there is an abnormality operation occurs.

14.9 Mild Dry Cooling Operation

- During multi split connection, Mild Dry Cooling Operation is disabled.

14.10 nanoe™X Operation

- Generate nanoe™X (water wrapped ion particle) to moisturize skin, provide deodorization & sterilization effect.
- nanoe™X operation start condition
 - During unit running at any operation mode in cooling operation only, if nanoe™X operation is activated, combination operation (operation mode + nanoe™X operation) starts.
 - During unit is OFF, if nanoe™X operation is activated, nanoe™X individual operation starts.(Note: nanoe™X is not applicable during heating operation)
- nanoe™X operation stop condition
 - When OFF/ON button is pressed to stop the operation.
 - When nanoe™X button is pressed.
 - When OFF Timer activates.
- nanoe™X operation pause condition
 - When indoor fan stop (during deice, odor cut control, thermostat off, etc.). nanoe™X operation resume after indoor fan restarts.
 - When indoor intake temperature $\geq 35^{\circ}\text{C}$ and $\leq 5^{\circ}\text{C}$. nanoe™X operation resume after indoor intake temperature $< 35^{\circ}\text{C}$ or $\geq 5^{\circ}\text{C}$ continuously for 6 minutes.
- Indoor fan control
 - During any operation mode combines with nanoe™X operation, fan speed follows respective operation mode. However, nanoe™X system enabled when fan speed ≥ 360 rpm to ensure proper negative ion distribution, nanoe™X system disabled when fan speed < 360 rpm.
 - During nanoe™X individual operation, fan speed follow remote control setting. Auto Fan Speed for nanoe™X individual operation is cooling medium fan. Powerful & Quiet is disabled during nanoe™X.
- Airflow direction control
 - During any operation mode combines with nanoe™X operation, airflow direction follows respective operation mode.
 - During nanoe™X individual operation, Air Swing follow remote control setting.
- Timer control
 - When ON Timer activates when unit stops, previous operation resumes and restored last saved nanoe™X operation status.
 - When ON Timer activates during any operation, no change on current operation.
 - When OFF Timer activates during any operation, all operation stops and the latest nanoe™X operation status is saved.
- Indicator
 - When nanoe™X starts, nanoe™X indicator ON.
- Remote control receiving sound
 - Normal Operation → nanoe™X Operation : Beep
 - nanoe™X Operation → Normal Operation : Beep
 - Stop → nanoe™X individual Operation : Beep
 - nanoe™X individual Operation → Stop : Long Beep
- Power failure
 - During nanoe™X individual operation, if power failure occurs, after power resumes, nanoe™X individual operation resumes immediately.
 - During combination operation, if power failure occurs, after power resumes, combination operation resume immediately.

- nanoe™X check mode
 - To enable nanoe™X check mode, during nanoe™X operation ON:

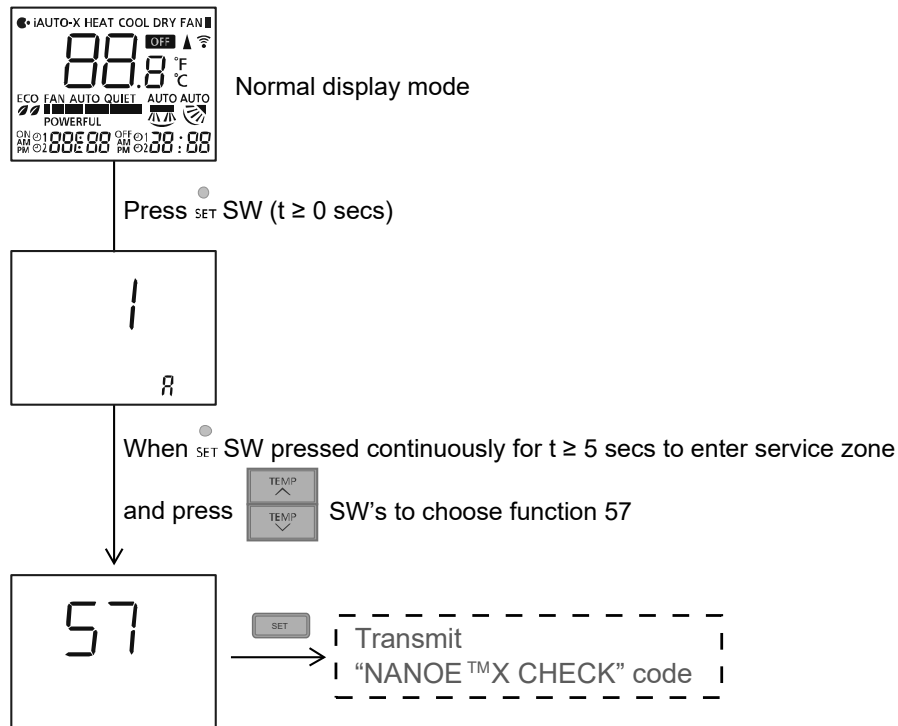

- During nanoe™X check mode, H67 is judged when disconnection detected. Timer LED blinks.
- nanoe™X Abnormal Detection
 - Disconnection Abnormality
 - Abnormal detection condition
 - Start from 1 sec after nanoe™X power ON, 6 secs has passed and in this 6 secs period, abnormal signal is detected continuously for 5.9 secs.
 - Action after abnormal detection condition fulfilled
 - Disconnection counters +1, nanoe™X power OFF for 5 minutes and then restart. However, according to action mode and disconnection counter, below will be implemented:
 - During nanoe™X Check Mode: Disconnection abnormality will judged when disconnection counter ≥ 1 . Abnormal code: H67 will memorized in EEPROM, Timer LED blinking and nanoe™X LED Off.
 - Other Than Above: Disconnection abnormality will judged when disconnection counter ≥ 3 . Abnormal code: H67 will memorized in EEPROM and nanoe™X LED OFF, Timer LED not blinking.
 - Disconnection counters clear condition >
 - Disconnection counter will be cleared when operation stop. (Not nanoe™X Check Mode)
 - nanoe™X Discharge Abnormality
 - Abnormal detection condition
 - After 30 minutes nanoe™X power ON, abnormal signal is being detected continuously for 5s.
 - Action after abnormal detection condition fulfilled
 - Abnormal discharge counter +1, nanoe™X power OFF for 30 minutes and then restart. When abnormal discharge counter ≥ 12 , abnormal code: H67 in analyze area (Area where abnormal code not displayed) will be memorized.
 - Abnormal discharge counters clear condition
 - Discharge counter will be cleared when operation become normal for 50 mins above or when operations stop.

15. Servicing Mode

15.1 Auto OFF/ON Button

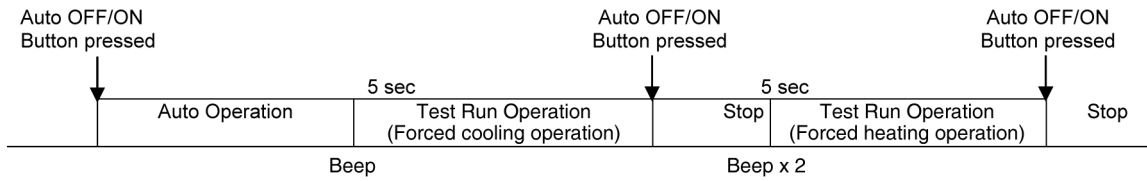

1 AUTO OPERATION MODE

The Auto operation will be activated immediately once the Auto OFF/ON button is pressed. This operation can be used to operate air conditioner with limited function if remote control is misplaced or malfunction.

2 TEST RUN OPERATION (FOR PUMP DOWN/SERVICING PURPOSE)

The Test Run operation will be activated if the Auto OFF/ON button is pressed continuously for more than 5 seconds. A “beep” sound will heard at the fifth seconds, in order to identify the starting of Test Run operation (Forced cooling operation). Within 5 minutes after Forced cooling operation start, the Auto OFF/ON button is pressed for more than 5 seconds. A 2 “beep” sounds will heard at the fifth seconds, in order to identify the starting of Forced heating operation.

The Auto OFF/ON button may be used together with remote control to set / change the advance setting of air conditioner operation.

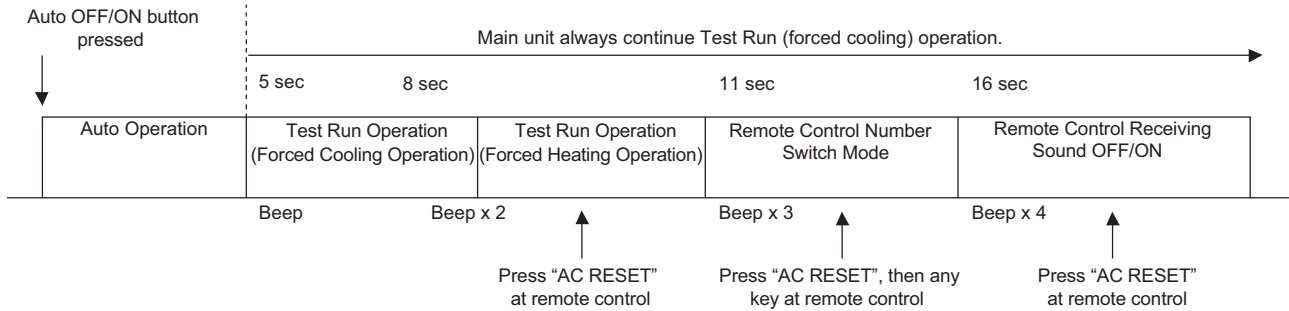

3 REMOTE CONTROL NUMBER SWITCH MODE

The Remote Control Number Switch Mode will be activated if the Auto OFF/ON button is pressed continuously for more than 11 seconds (3 “beep” sounds will occur at 11th seconds to identify the Remote Control Number Switch Mode is in standby condition) and press “AC RESET” button and then press any button at remote control to transmit and store the desired transmission code to the EEPROM.

There are 4 types of remote control transmission code could be selected and stored in EEPROM of indoor unit. The indoor unit will only operate when received signal with same transmission code from remote control. This could prevent signal interference when there are 2 or more indoor units installed nearby together. To change remote control transmission code, short or open jumpers at the remote control printed circuit board.

JA	Remote Control Printed Circuit Board			JB
	Jumper A (J-A)	Jumper B (J-B)	Remote Control No.	
Short	Open	A (Default)		
Open	Open	B		
Short	Short	C		
Open	Short	D		

- During Remote Control Number Switch Mode, press any button at remote control to transmit and store the transmission code to the EEPROM.

4 REMOTE CONTROL RECEIVING SOUND OFF/ON MODE

The Remote Control Receiving Sound OFF/ON Mode will be activated if the Auto OFF/ON button is pressed continuously for more than 16 seconds (4 “beep” sounds will occur at 16th seconds to identify the Remote Control Receiving Sound Off/On Mode is in standby condition) and press “AC Reset” button at remote control.





Press “Auto OFF/ON button” to toggle remote control receiving sound.

- a) Short “beep”: Turn OFF remote control receiving sound.
- b) Long “beep”: Turn ON remote control receiving sound.

After Auto OFF/ON Button is pressed, the 20 seconds counter for Remote Control Receiving Sound OFF/ON Mode is restarted.

15.2 Heat Only Operation

15.2.1 How to Activate/Deactivate Heat only Operation

- Use remote controller to set heating only operation. When the unit in standby mode, follow the steps below:
 - a) Press  continuously for more than 5 seconds to enter special setting mode.
 - b) Press  to choose function 61, and then press  or  to set “01”. (To enable the “Heat Only” mode) or “00” (To disable the “Heat Only” mode).
 - c) Press  to activate “Heating only operation” or deactivate “Heating only operation”.

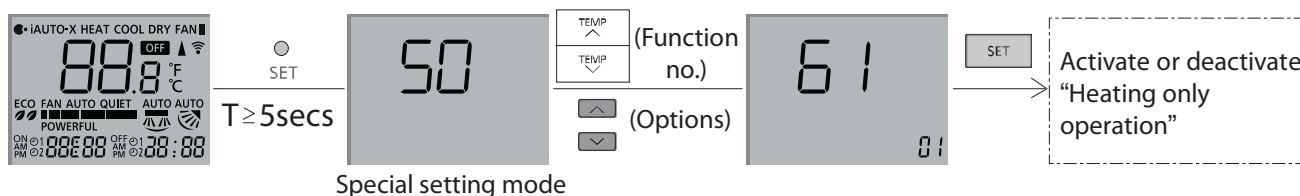

15.2.2 Operation mode during Heating Only Operation

- The table below shows the operation mode comparison when Heating Only Operation Mode Activated and Deactivated.

Operation Mode	Heating Only Operation Mode Activated	Heating Only Operation Mode Deactivated
AUTO	After 30s sampling, regardless of the indoor intake or outdoor intake temperature judgment, the unit will run Heating operation.	After 30s sampling, the unit will judge the operation mode base on remote controller temperature setting and Indoor Intake Sensor (New Auto Mode) or Outdoor Intake Sensor (Old Auto Mode).
HEAT	The unit will run Heating operation.	The unit will run Heating operation.
COOL	The unit will stop and Power LED blinking.	The unit will run Cooling operation.
DRY	The unit will stop and Power LED blinking.	The unit will run Cooling Dry operation.
NANOE Stand-alone	The unit will stop and Power LED blinking.	The unit will run Nanoe Stand-alone operation.
Force Cooling	The unit will run Force Cooling Operation for X_CTRYTM [15] minutes	The unit will run Force Cooling operation.
Force Heating	The unit will run Force Heating operation.	The unit will run Force Heating operation.
AUTO (with Timer)	The unit will turn ON by the timer and run Auto Operation. After 30s sampling, regardless of the indoor intake or outdoor intake temperature judgment, the unit will run Heating operation.	The unit will turn ON by the timer and run Auto Operation. After 30s sampling, the unit will judge the operation mode base on remote controller temperature setting and Indoor Intake Sensor (New Auto Mode) or Outdoor Intake Sensor (Old Auto Mode).
HEAT (with Timer)	The unit will turn ON by the timer and run Heating Operation.	The unit will turn ON by the timer and run Heating Operation.
COOL (with Timer)	The unit will not turn ON by the timer. Power LED blinking.	The unit will turn ON by the timer and run Cooling Operation.
DRY (with Timer)	The unit will not turn ON by the timer. Power LED blinking.	The unit will turn ON by the timer and run Cooling Dry Operation.
Cooling Test Mode	The unit will stop and Power LED blinking.	The unit will operate according to specify Cooling test mode operation parameter.
Heating Test Mode	The unit will operate according to specify Heating test mode operation parameter.	The unit will operate according to specify Heating test mode operation parameter.

15.3 Remote Control Button

15.3.1 SET Button

- To check remote control transmission code and store the transmission code to EEPROM.
 - Press "Set" button by using pointer.
 - Press "Timer Set" button until a "beep" sound is heard as confirmation of transmission code change.
 - LCD returns to original display if remote control does not operate for 30 seconds.

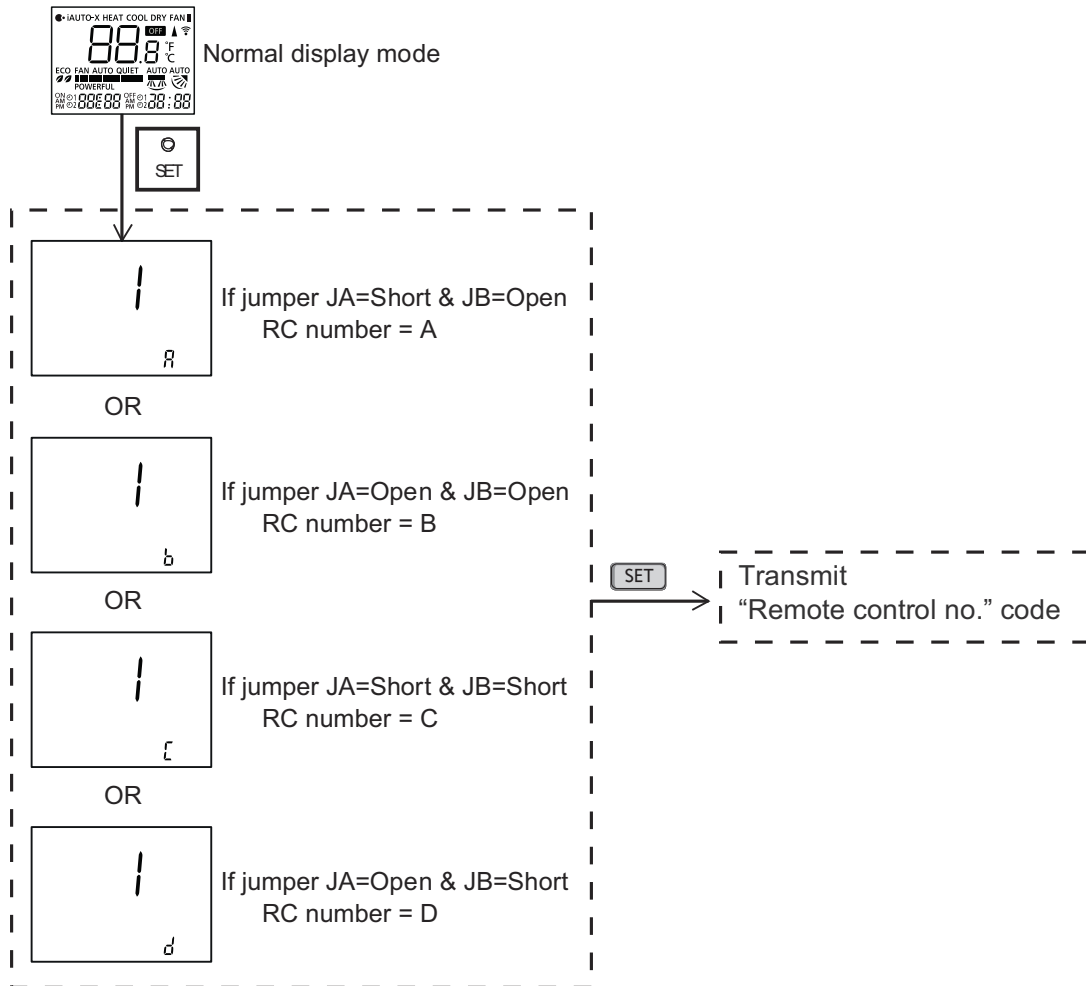

- Press **CANCEL** SW, special setting is immediately cancelled and normal mode starts.
- If no SW is pressed for 30 secs, then special setting mode is cancelled and normal mode starts.

- Under this function, only **TEMP** **TEMP**, **SET**, **CANCEL** and **RC** **RESET** SW's are effective.

- To limit set temperature range for COOL & DRY, HEAT, AUTO mode.
 - Press “Set” button by using pointer.
 - Press TEMP increment or decrement button to choose No. 3.
 - Press Timer increment or decrement button to select desired temperature low limit of set temperature for COOL & DRY mode.

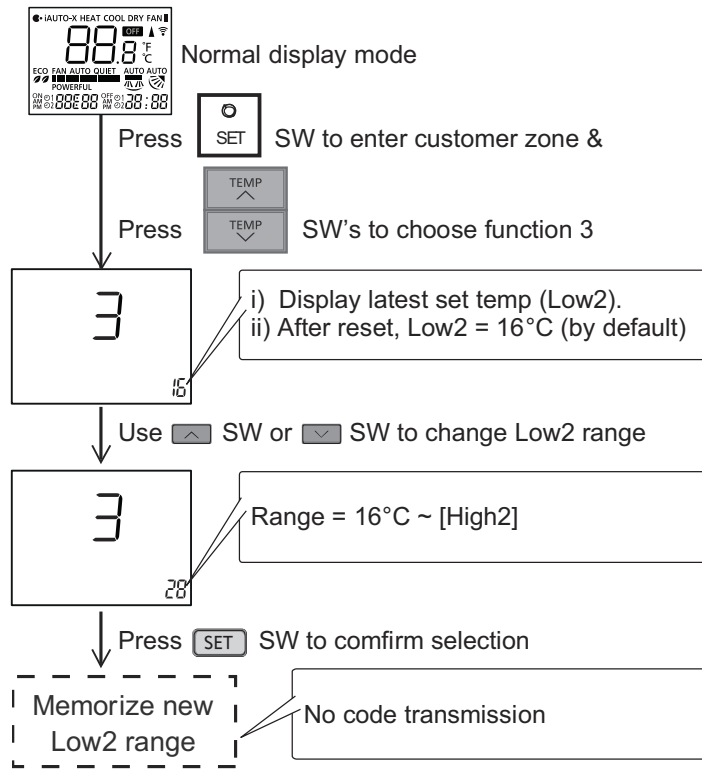

- Press Timer Set button to confirm low limit selection.
- Press TEMP increment or decrement button to choose No. 4.
- Press Timer decrement or increment button to select desired temperature high limit of set temperature for COOL & DRY mode.

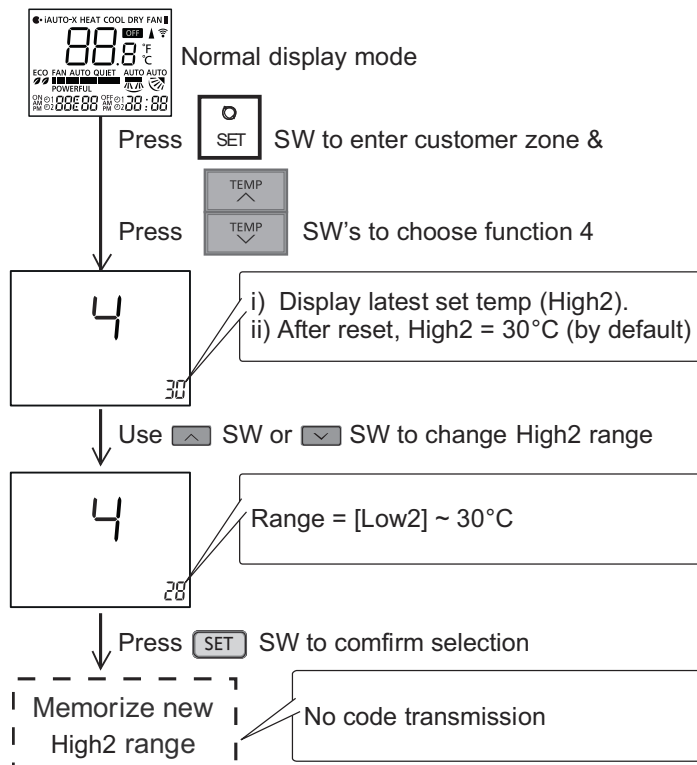

- Press Timer Set button to confirm high limit selection.

- Press TEMP increment or decrement button to choose No. 5.
- Press Timer increment or decrement button to select desired temperature low limit of set temperature for HEAT mode.

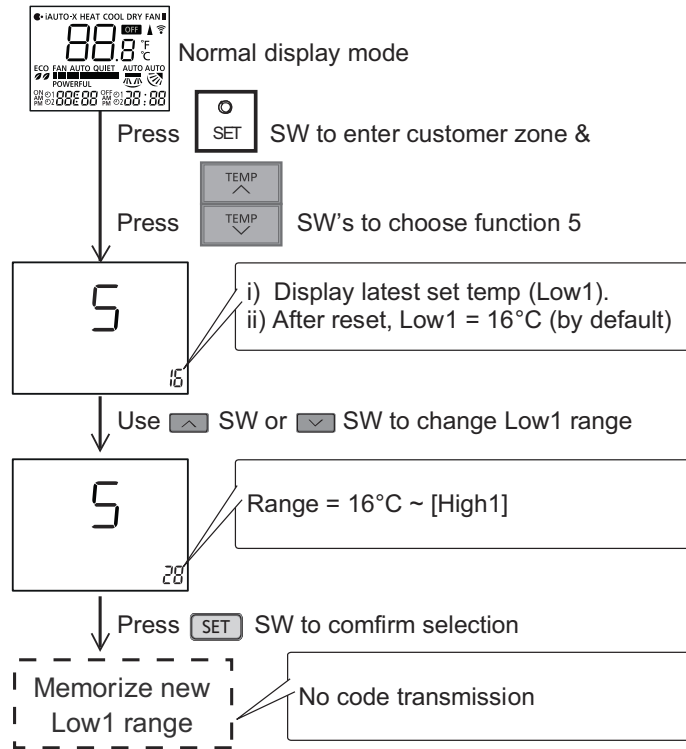

- Press Timer Set button to confirm low limit selection.
- Press TEMP increment or decrement button to choose No. 6.
- Press Timer decrement or increment button to select desired temperature high limit of set temperature for HEAT mode.

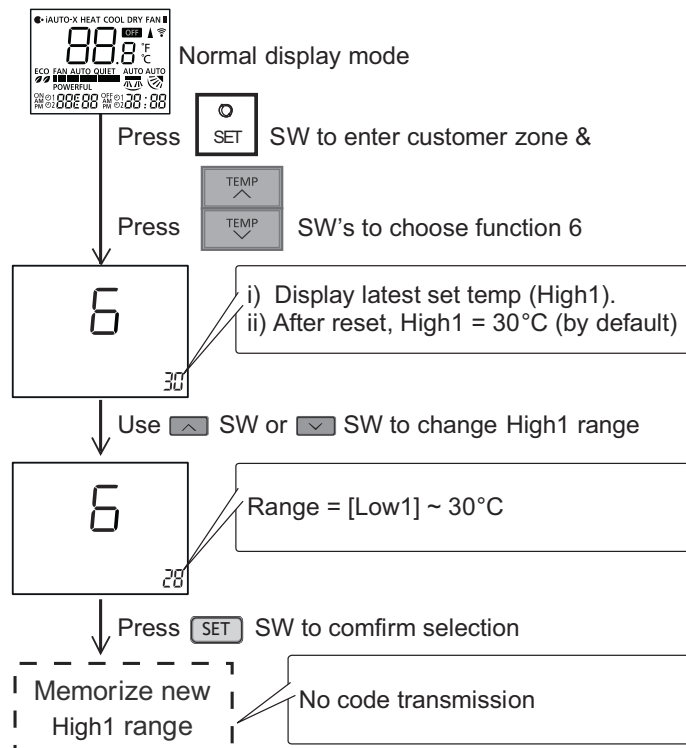

- Press Timer Set button to confirm high limit selection.

- Press TEMP increment or decrement button to choose No. 12.
- Press Timer increment or decrement button to select desired temperature low limit of set temperature for AUTO mode.

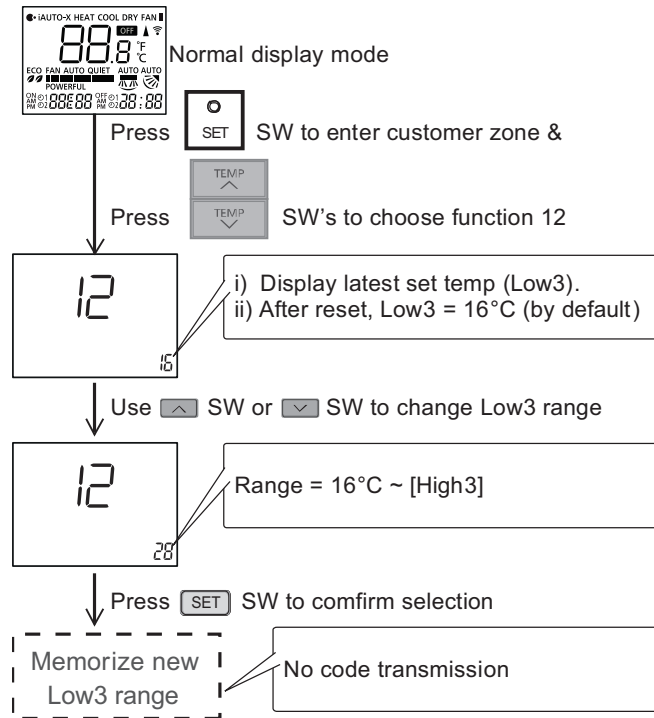

- Press Timer Set button to confirm low limit selection.
- Press TEMP increment or decrement button to choose No. 13.
- Press Timer decrement or increment button to select desired temperature high limit of set temperature for AUTO mode.

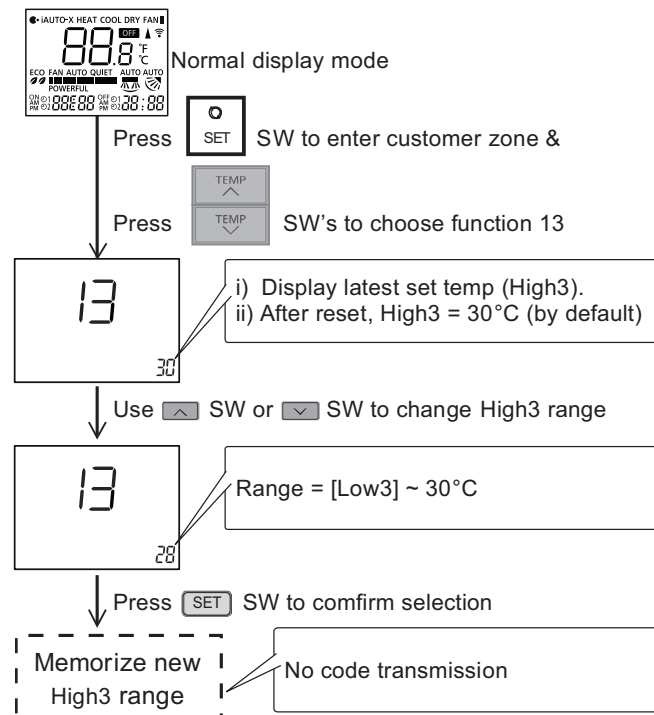

- Press Timer Set button to confirm high limit selection.
- LCD returns to original display if remote control does not operate for 30 seconds or press Timer Cancel button.

15.3.2 RESET (RC)

- To clear and restore the remote control setting to factory default.
 - Press once to clear the memory

15.3.3 RESET (AC)

- To restore the unit's setting to factory default.
 - Press once to restore the unit's setting.

15.3.4 TIMER

- To change indoor unit indicators' intensity:
 - Press continuously for 5 seconds.

15.3.5 TIMER

- To change remote control display from Degree Celsius (°C) to Degree Fahrenheit (°F).
 - Press continuously for 10 seconds.

15.3.6 Customization mode

1 LCD display area:

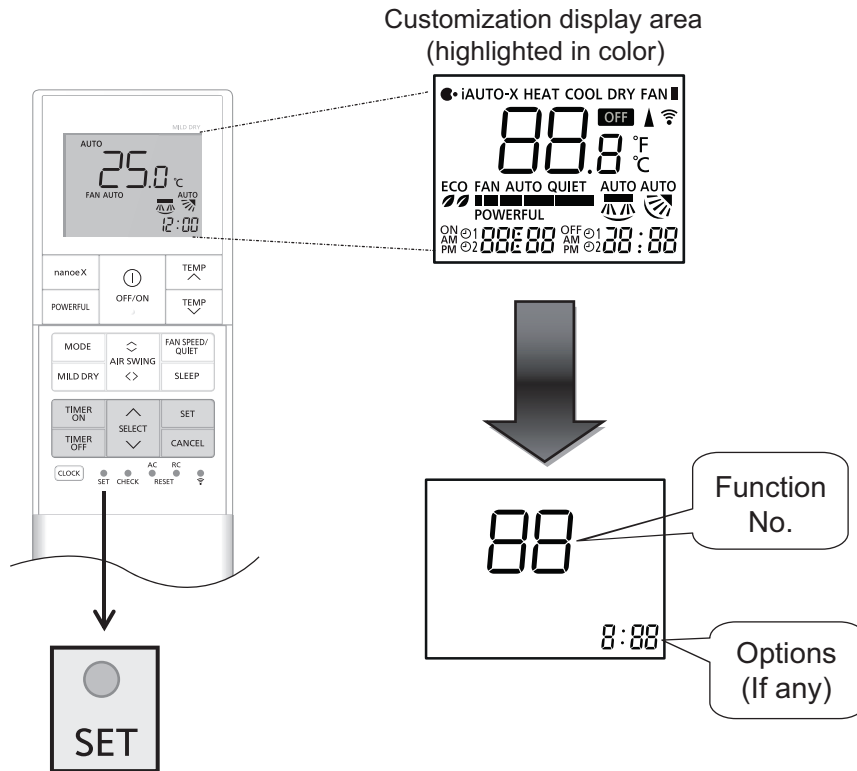

2 Cannot enter this customization mode under the following conditions:

- ① Operation ON.
- ② Under [Real/ON/OFF] time setting mode.

3 To enter Customer zone:

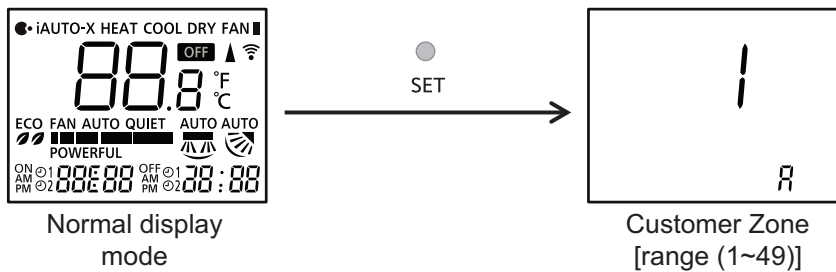

4 To enter Service zone: (Press SET continuously for T ≥ 5 secs)

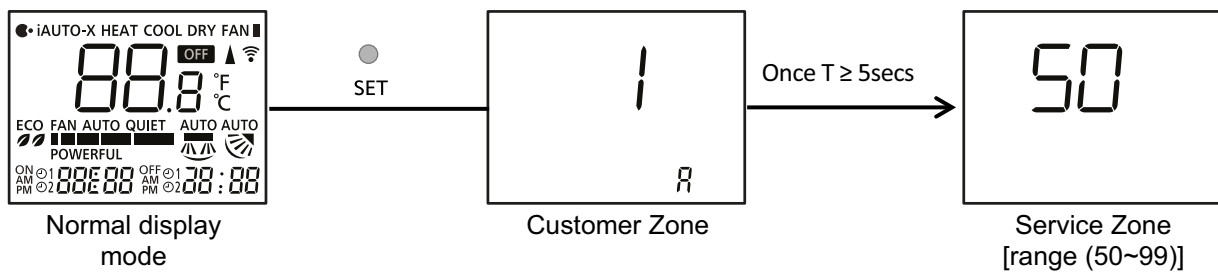

5 Function & Options list:

Note: The functions described in the table may not be applicable to the model and may subject to change without further notice.

		Customization		Options	Remark
		No	Name		
Customer Zone		1	Remote control number selection	A, B, C, D	
		2	Solar radiation sensitivity level adjustment	1, 2, 3, 4, 5	
		3	[iAUTO-X/iAUTO/iCOMF, Cool & Dry] mode set temperature [Low2] selection	16°C ~ [High2]	
		4	[iAUTO-X/iAUTO/iCOMF, Cool & Dry] mode set temperature [High2] selection	[Low2] ~ 30°C	
		5	Heat mode set temperature Low1 selection	16°C ~ [High1]	
		6	Heat mode set temperature High1 selection	[Low1] ~ 30°C	
		7	Filter cleaning selection	00 – Disable 01 – Enable	
		8	nanoe/nanoe-G default ON selection	00 – Disable 01 – Enable	
		9	Dust sensor monitoring & LED selection	00 – Disable 01 – Enable	
		10	Auto restart selection	00 – Disable 01 – Enable	
		11	Dust sensor sensitivity level adjustment	1, 2, 3	
		12	Auto mode set temperature Low3 selection	16°C ~ [High3]	
		13	Auto mode set temperature High3 selection	[Low3] ~ 30°C	
		14	Indoor unit installation position selection	ct – Center lt – Left rt – Right	
		15	ECO status memorize selection	00 – Disable 01 – Enable	
		16 ~ 49	Reserve		
Service Zone		50	ECO demo ON	None (No display)	
		51	Light sensor check	None (No display)	
		52	nanoe-G / ECO sensor check	None (No display)	
		53	DOA check	None (No display)	
		54	Odor cut control selection	00 – Disable 01 – Enable	
		55	Frequency tolerance selection	03 – ±3Hz 07 – ±7Hz	
		56	Fixed fan speed selection during heat mode compressor OFF	00 – Disable 01 – Enable	
		57	nanoe check	None (No display)	
		58	Heat mode thermo shift adjustment	-3°C ~ 3°C	
		59	Others (Cool & Dry) mode thermo shift adjustment	-3°C ~ 3°C	
		60	Deice start determination judgment temperature switching	00 – No 01 – Yes	
		61	Cool mode disable selection	00 – No 01 – Yes	
		62	Heat mode disable selection	00 – No 01 – Yes	
		63	Base pan heater selection	A – Base pan A b – Base pan B	
		64	Disable fan speed reduction during cool mode thermo-Off	00 – No 01 – Yes	
	65	LED smart OFF selection	00 – Disable 01 – Enable		
	66	nanoe-G ON/OFF duration selection	01 – Pattern 1 02 – Pattern 2 03 – Pattern 3 04 – Pattern 4		
	67	Operation OFF deice function selection	00 – Disable 01 – Enable		

		Customization		Options	Remark
		No	Name		
Service Zone	68	Compressor frequency change speed selection		01 – Pattern 1 02 – Pattern 2 03 – Pattern 3	
	69	Up/Down air swing upper limit restriction selection		00 – Disable 01 – Enable	
	70	Failure diagnosis mode disable		None (No display)	
	71	Compressor Fhmax setting selection		01 – Offset 1 02 – Offset 2 03 – Offset 3	
	72	Compressor Max Fc setting selection		00 – Disable 01 – Enable	
	73 ~ 99	Reserve			

16. Exploded View and Replacement Parts List

16.1 Indoor Unit

16.1.1 CS-MZ16ZKE

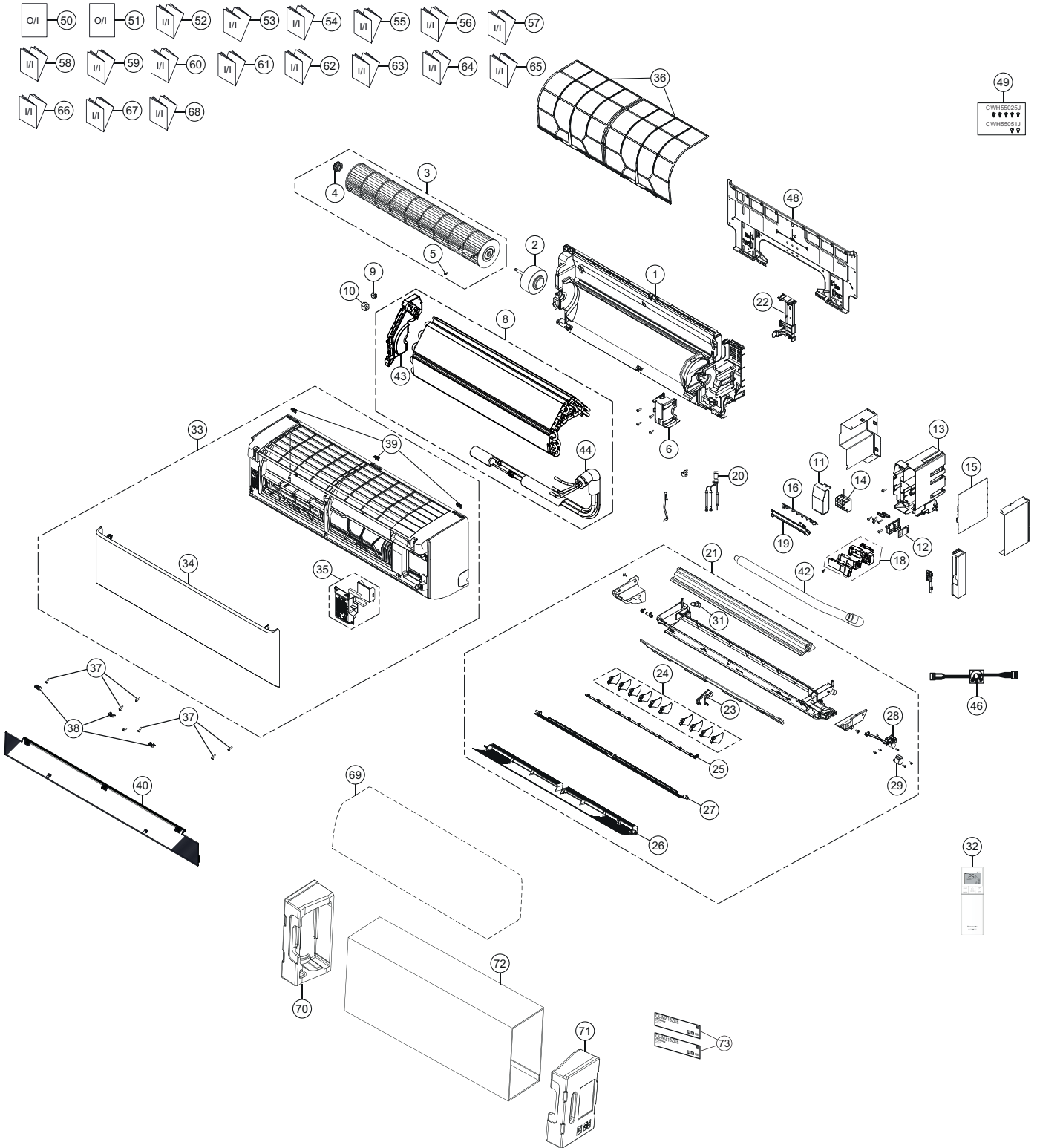

Note
 The above exploded view is for the purpose of parts disassembly and replacement.
 The non-numbered parts are not kept as standard service parts.

SAFETY	REF. NO.	PART NAME & DESCRIPTION	QTY.	CS-MZ16ZKE	REMARK
	1	CHASSIS COMPLETE	1	ACXD50C04160	
⚠	2	FAN MOTOR	1	L6CBYYL0435	O
	3	CROSS-FLOW FAN COMPLETE	1	ACXH02C01480	
	4	BEARING ASSY	1	CWH64K1006	
	5	SCREW - CROSS-FLOW FAN	1	CWH551146	
	6	FAN MOTOR BRACKET	1	ACXD54-04360	
	8	EVAPORATOR	1	ACXB30C32540	O
	9	FLARE NUT (LIQUID)	1	CWT251048	
	10	FLARE NUT (GAS)	1	CWT251049	
	11	CONTROL BOARD COVER	1	ACXH13-08680	
⚠	12	ELECTRONIC CONTROLLER- WIFI	1	ACXA73-45970	O
	13	CONTROL BOARD CASING	1	ACXH10-08620	
⚠	14	TERMINAL BOARD COMPLETE	1	ACXA28C05870	O
⚠	15	ELECTRONIC CONTROLLER - MAIN	1	ACXA73C91640	O
⚠	16	ELECTRONIC CONTROLLER-INDICATOR	1	ACXA73-37110	O
⚠	18	GENERATOR COMPLETE	1	ACXH94C01760	O
	19	INDICATOR HOLDER	1	ACXD93-22430	
⚠	20	SENSOR COMPLETE	1	CWA50C2664	O
	21	DISCHARGE GRILLE COMPLETE	1	ACXE20C06080	O
	22	BACK COVER CHASSIS	1	ACXD93-22420	
	23	FULCRUM	1	ACXH62-00790	
	24	VERTICAL VANE	10	ACXE24-04000	
	25	CONNECTING BAR	1	ACXE26-02550	
	26	HORIZONTAL VANE COMPLETE - OUTER	1	ACXE24C04660	
	27	HORIZONTAL VANE COMPLETE - INNER	1	ACXE24C04670	
⚠	28	AIR SWING MOTOR ASSY	1	ACXA98K00220	O
⚠	29	AIR SWING MOTOR	1	ACXA98-02420	O
	31	CAP - DRAIN TRAY	1	CWH521096	
⚠	32	REMOTE CONTROL COMPLETE	1	ACXA75C23690	O
	33	FRONT GRILLE COMPLETE	1	ACXE10C13660	O
	34	INTAKE GRILLE COMPLETE	1	ACXE22K09860	
	35	GRILLE DOOR COMPLETE	1	ACXE14C01440	
	36	AIR FILTER	2	ACXD00-02990	
	37	SCREW - FRONT GRILLE	6	XTT4+16CFJ	
	38	CAP - FRONT GRILLE	3	ACXH52-04000	
	39	PARTICULAR PIECE -LOCK	3	ACXD93-18690	
	40	PARTICULAR PLATE	1	ACXD90-26390	
	42	DRAIN HOSE	1	ACXH85-00211	
	43	BOX SHAPED PLATE	1	ACXD66-03420	
	44	TUBE ASSY-COMPLETE	1	ACXT00C34830	
⚠	46	LEAD WIRE-COMPLETE	1	ACXA60C94030	O
	48	INSTALLATION PLATE	1	ACXH36-00840	
	49	BAG COMPLETE - INSTALLATION SCREW	1	CWH82C1705	
	50	OPERATING INSTRUCTION	1	ACXF55-34740	
	51	OPERATING INSTRUCTION	1	ACXF55-34750	
	52	INSTALLATION INSTRUCTION	1	ACXF60-51050	
	53	INSTALLATION INSTRUCTION	1	ACXF60-51060	

SAFETY	REF. NO.	PART NAME & DESCRIPTION	QTY.	CS-MZ16ZKE	REMARK
	54	INSTALLATION INSTRUCTION	1	ACXF60-51070	
	55	INSTALLATION INSTRUCTION	1	ACXF60-51080	
	56	INSTALLATION INSTRUCTION	1	ACXF60-51090	
	57	INSTALLATION INSTRUCTION	1	ACXF60-51100	
	58	INSTALLATION INSTRUCTION	1	ACXF60-51110	
	59	INSTALLATION INSTRUCTION	1	ACXF60-51120	
	60	INSTALLATION INSTRUCTION	1	ACXF60-51130	
	61	INSTALLATION INSTRUCTION	1	ACXF60-51140	
	62	INSTALLATION INSTRUCTION	1	ACXF60-51150	
	63	INSTALLATION INSTRUCTION	1	ACXF60-51160	
	64	INSTALLATION INSTRUCTION	1	ACXF60-51170	
	65	INSTALLATION INSTRUCTION	1	ACXF60-51180	
	66	INSTALLATION INSTRUCTION	1	ACXF60-51190	
	67	INSTALLATION INSTRUCTION	1	ACXF60-51200	
	68	INSTALLATION INSTRUCTION	1	ACXF60-51210	
	69	BAG	1	CWG861497	
	70	SHOCK ABSORBER - LEFT	1	ACXG70-12960	
	71	SHOCK ABSORBER - RIGHT	1	ACXG70-12970	
	72	C.C.CASE	1	ACXG50-57103	
	73	MODEL LABEL	2	ACXF87-02880	

(NOTE)

- All parts are supplied from PAPAMY, Malaysia (Vendor Code: 00029488).
- "O" marked parts are recommended to be kept in stock.

16.1.2 CS-MTZ16ZKE

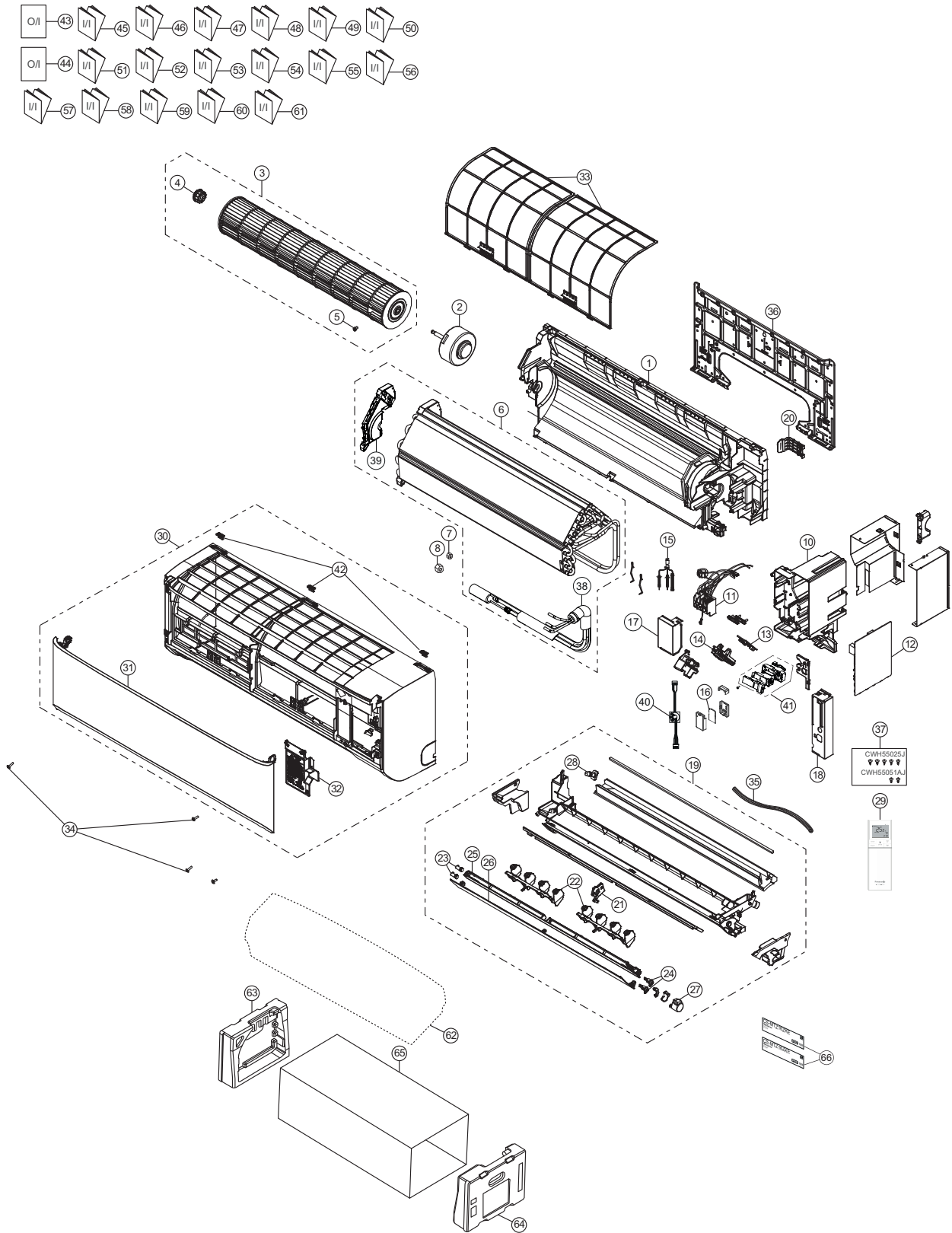

Note
 The above exploded view is for the purpose of parts disassembly and replacement.
 The non-numbered parts are not kept as standard service parts.

SAFETY	REF. NO.	PART NAME & DESCRIPTION	QTY.	CS-MTZ16ZKE	REMARK
	1	CHASSIS COMPLETE	1	ACXD50C04620	
⚠	2	FAN MOTOR	1	L6CBYYL0311	O
	3	CROSS-FLOW FAN COMPLETE	1	ACXH02C01190	
	4	BEARING ASSY	1	CWH64K1006	
	5	SCREW - CROSS-FLOW FAN	1	CWH551146	
	6	EVAPORATOR	1	ACXB30C36750	O
	7	FLARE NUT (LIQUID)	1	CWT251063	
	8	FLARE NUT (GAS)	1	CWT251049	
	10	CONTROL BOARD CASING	1	ACXH10-07900	
⚠	11	TERMINAL BOARD COMPLETE	1	ACXA28C05870	O
⚠	12	ELECTRONIC CONTROLLER - MAIN	1	ACXA73C94240	O
⚠	13	ELECTRONIC CONTROLLER-INDICATOR	1	ACXA73-34560	O
	14	INDICATOR HOLDER	1	ACXD93-20781	
⚠	15	SENSOR COMPLETE	1	CWA50C2664	O
	16	ELECTRONIC CONTROLLER- WIFI	1	ACXA73-45970	
	17	CONTROL BOARD COVER	1	ACXH13-08190	
	18	CONTROL BOARD COVER	1	ACXH13-08200	
	19	DISCHARGE GRILLE COMPLETE	1	ACXE20C08210	O
	20	BACK COVER CHASSIS	1	ACXD93-18680	
	21	FULCRUM	1	ACXH62-00680	
	22	VERTICAL VANE	2	ACXE24-03470	
	23	SHAFT	2	ACXH63-01540	
	24	SHAFT	2	ACXH63-01570	
	25	HORIZONTAL VANE -INNER	1	ACXE24-03710	
	26	HORIZONTAL VANE -OUTER	1	ACXE24-03720	
⚠	27	AIR SWING MOTOR	1	ACXA98-03560	O
	28	CAP - DRAIN TRAY	1	CWH521259	
⚠	29	REMOTE CONTROL COMPLETE	1	ACXA75C23671	O
	30	FRONT GRILLE COMPLETE	1	ACXE10C17550	
	31	INTAKE GRILLE COMPLETE	1	ACXE22C04140	O
	32	GRILLE DOOR COMPLETE	1	ACXE14C01310	
	33	AIR FILTER	2	ACXD00-02860	
	34	SCREW - FRONT GRILLE	3	XTT4+16CFJ	
	35	DRAIN HOSE	1	ACXH85-00201	
	36	INSTALLATION PLATE	1	ACXH36-00650	
	37	BAG COMPLETE - INSTALLATION SCREW	1	CWH82C1705	
	38	TUBE ASSY-COMPLETE	1	ACXT00C35380	
	39	BOX SHAPED PLATE	1	ACXD66-02910	
⚠	40	LEAD WIRE-COMPLETE	1	ACXA60C96480	O
⚠	41	GENERATOR COMPLETE	1	ACXH94C01590	O
	42	PARTICULAR PIECE -LOCK	3	ACXD93-18690	
	43	OPERATING INSTRUCTION	1	ACXF55-34760	
	44	OPERATING INSTRUCTION	1	ACXF55-34770	
	45	INSTALLATION INSTRUCTION	1	ACXF60-50880	
	46	INSTALLATION INSTRUCTION	1	ACXF60-50890	
	47	INSTALLATION INSTRUCTION	1	ACXF60-50900	
	48	INSTALLATION INSTRUCTION	1	ACXF60-50910	

SAFETY	REF. NO.	PART NAME & DESCRIPTION	QTY.	CS-MTZ16ZKE	REMARK
	49	INSTALLATION INSTRUCTION	1	ACXF60-50920	
	50	INSTALLATION INSTRUCTION	1	ACXF60-50930	
	51	INSTALLATION INSTRUCTION	1	ACXF60-50940	
	52	INSTALLATION INSTRUCTION	1	ACXF60-50950	
	53	INSTALLATION INSTRUCTION	1	ACXF60-50960	
	54	INSTALLATION INSTRUCTION	1	ACXF60-50970	
	55	INSTALLATION INSTRUCTION	1	ACXF60-50980	
	56	INSTALLATION INSTRUCTION	1	ACXF60-50990	
	57	INSTALLATION INSTRUCTION	1	ACXF60-51000	
	58	INSTALLATION INSTRUCTION	1	ACXF60-51010	
	59	INSTALLATION INSTRUCTION	1	ACXF60-51020	
	60	INSTALLATION INSTRUCTION	1	ACXF60-51030	
	61	INSTALLATION INSTRUCTION	1	ACXF60-51040	
	62	BAG	1	ACXG86-00190	
	63	SHOCK ABSORBER (LEFT)	1	ACXG70-11650	
	64	SHOCK ABSORBER (RIGHT)	1	ACXG70-11660	
	65	C.C.CASE	1	ACXG50-54753	
	66	MODEL LABEL	2	ACXF87-02870	

(NOTE)

- All parts are supplied from PAPAMY, Malaysia (Vendor Code: 00029488).
- "O" marked parts are recommended to be kept in stock.